



Healing the Environment and Transforming Industry

Global technology company focused on
water remediation and **climate change**

Headquartered in Ottawa (Ontario), Canada





Company Profile

10 years of Research and Development

Third party research collaboration:

- **Toronto Metropolitan University**
- **US ARMY Corp of Engineers**
- **Natural Resources Canada**
- **National Research Council**
- **Guelph University**
- **Carleton University**
- **MOTE Marine Laboratory**
- **University of South Florida**
- **Ocean Networks Canada**
- **University of Victoria**

Innovations



35 new patents in the last five years

More than 25 patent applications pending

Our Disruptive Discovery – EMF Technology

Changes properties of water

- subtle stimuli with **minimal energy** (<1 W)
- cascading equilibrium propagation
- **Large scale** - radius of 220 meters.



220 m

Ability to change liquid's:

- **viscosity**
- **surface tension**
- **gas transfer rate**

Stimulus for new liquid equilibrium structure, unlocking large-scale effects with minimal energy



Liquid equilibrium structure
X Viscosity and Y Surface tension

Liquid equilibrium structure with EMF
Changes in viscosity and surface tension

CASE: in open waterbodies
= 2X Gas Transfer



EMF Device



EMF Device (< 1 Watt) – 10 kg

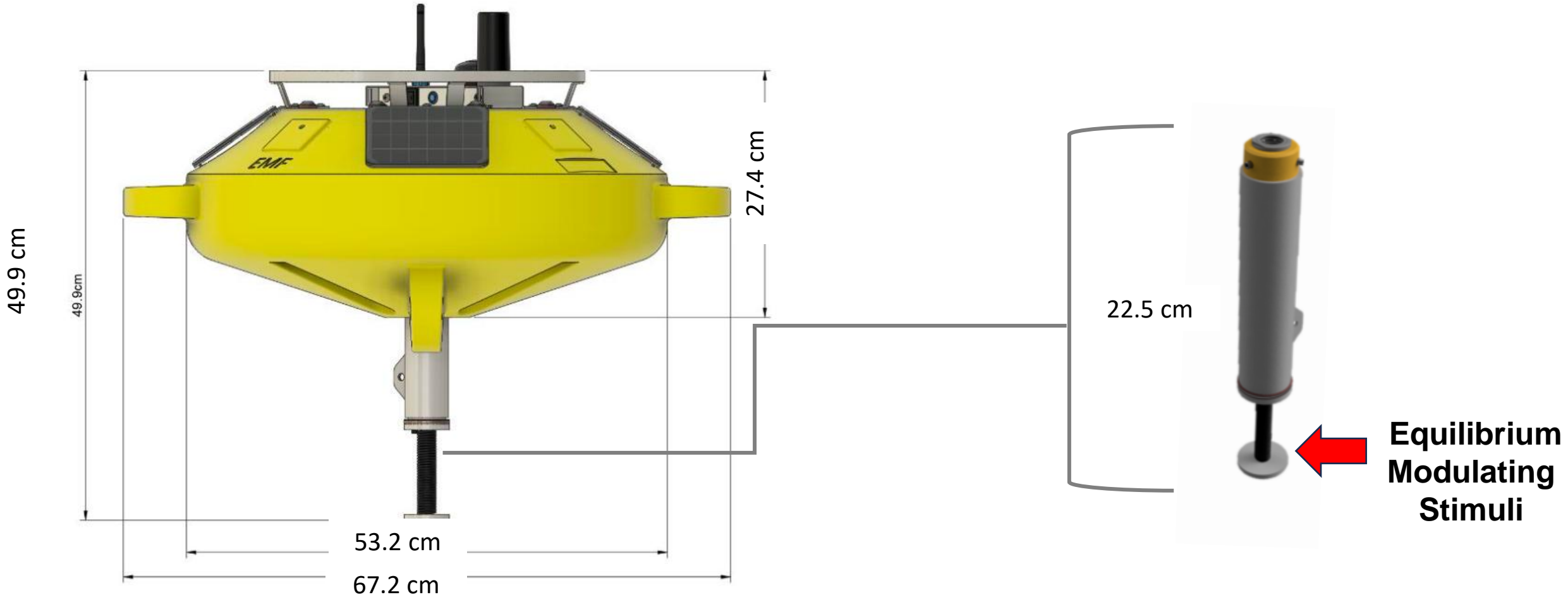



EMF Device Deployment and Maintenance



Easy installation with no large infrastructure.

Easy maintenance every 2 weeks



Background Mechanisms Driving Cyanobacteria Bloom



Excessive Nutrients

Nightly Hypoxic Conditions →



Aerobic Nitrification Bacteria
Ammonia Oxidizing Bacteria



Ammonia Availability → Cyanobacteria Competitiveness → Cyanobacteria Bloom



Background Mechanisms Driving Cyanobacteria Bloom



Excessive Nutrients



Photosynthetic Activity



Dissolved Carbon Dioxide



pH (>9.5)



Zooplankton



Phytoplankton Consumption



Effects of Improved Oxygenation **24/7**

 Oxidation-Reduction Potential (ORP)

 Nitrification bacteria and methanotrophs

 Anaerobic bacteria and processes

Ammonia  Nitrate

 Mass fish kills



Suppress Cyanobacteria, **Do Not Kill**

- ↓ Competitiveness of cyanobacteria
- ↑ Competitiveness of diatoms and green algae
- ↑ Zooplankton
- ↑ Fish, molluscs, crustaceans

Aquatic food chain - exit channel for excessive nutrients



Case Studies

Reservoirs, Lakes, Ponds

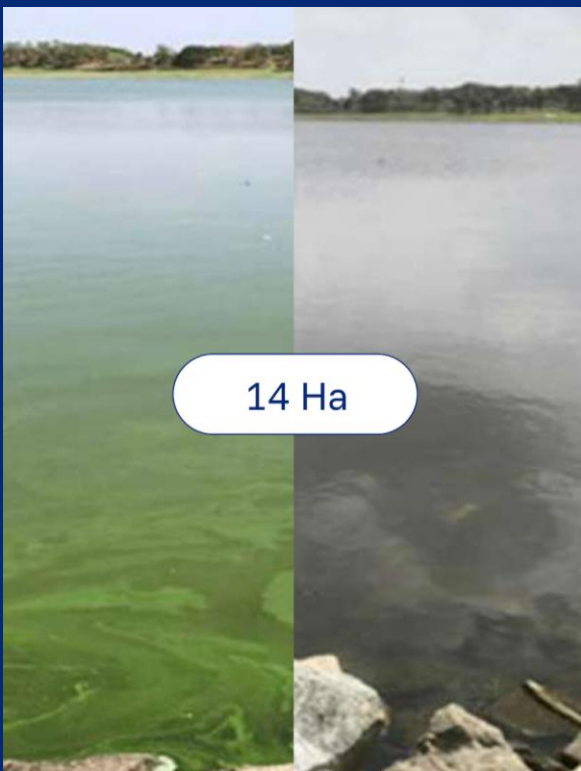

THAILAND Amata Spring Golf Course

Problems

- **Mass fish kills**
- Eutrophication
- Cyanobacteria blooms

Results after 6 weeks

No fish kills

BOD	70% ↓	Chlorophyll	85% ↓
COD	40% ↓	P	80% ↓
N	70% ↓	Ammonia	70% ↓

Results after 6-weeks

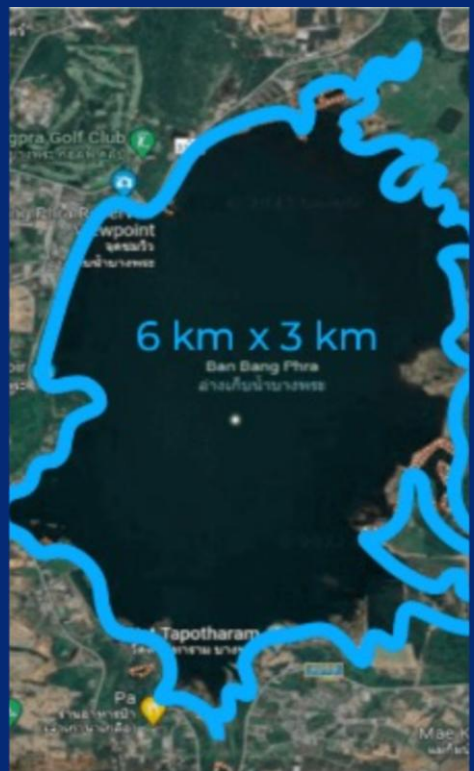

THAILAND Royal Irrigation Department

Problems

- Eutrophication
- **Cyanobacteria blooms**

Results after 2 weeks

Cyanobacteria 83% ↓
Diatoms 65% ↑



Reservoirs, Lakes, Ponds

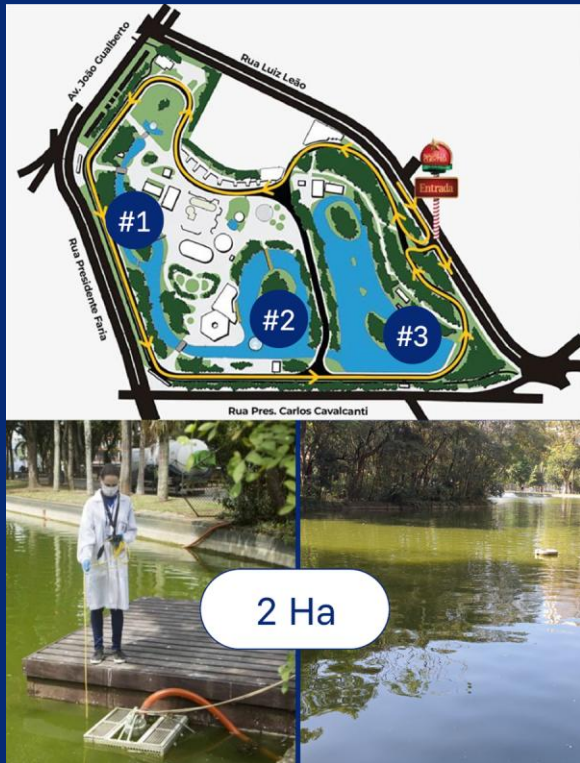

BRAZIL SANEPAR utility – 11 million residents

Problems

- Cyanobacteria
- Organic sludge accumulation
- Green colour
- Occasional fish-kills

Results after 4 months

With one EMF unit in lake #3

Cyanobacteria concentration **↓ 97%**

Over 500m³ of sludge digested

=

US\$65,570 saved on dredging



Wastewater and Sewage Processing

- ↑ Aerobically digest organic sludge in-situ
- ↑ Facility processing capacity
- ↓ Expensive dredging
- ↓ Greenhouse Gas emissions



Deployment in Brazil

ETE in Curitiba with 5 lagoons:

- 10% of sludge digested, 3037 m³ = saving of \$137,000 in 4 months
- Retention time improved by 1.5 days
- Improvement on all effluent parameters

ETE in Curitiba with UASB reactor + lagoon:

- 11% of sludge digested, 5425 m³ = saving of \$225,000 in 4 months
- Improvement on all effluent parameters





Port Lambton Sewage Lagoons, Canada

SIZE: 6 Ha | DEPTH: 2 m | DURATION: 5 months

Problems:

- Accumulation of sludge
- Odour
- Algae blooms

Results in treated South Lagoon:

- Algae bloom suppressed in 137 days
- Reduction in:
 - ↓ Overall Odour
 - ↓ Sludge accumulation
 - ↓ 88% E-coli
 - ↓ 7% TSS
 - ↓ 69% BOD
 - ↓ 79% Ammonia

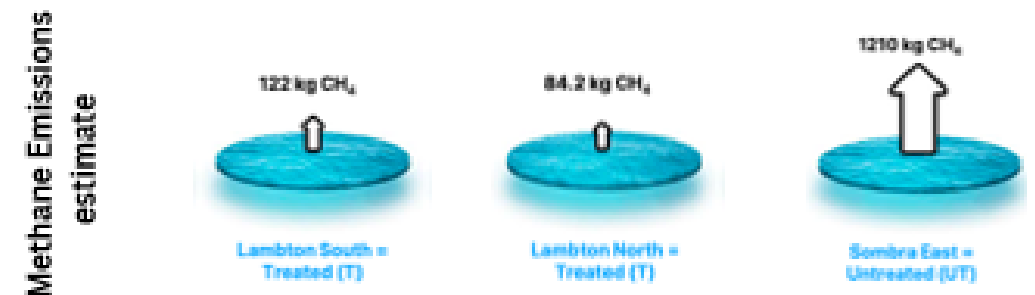
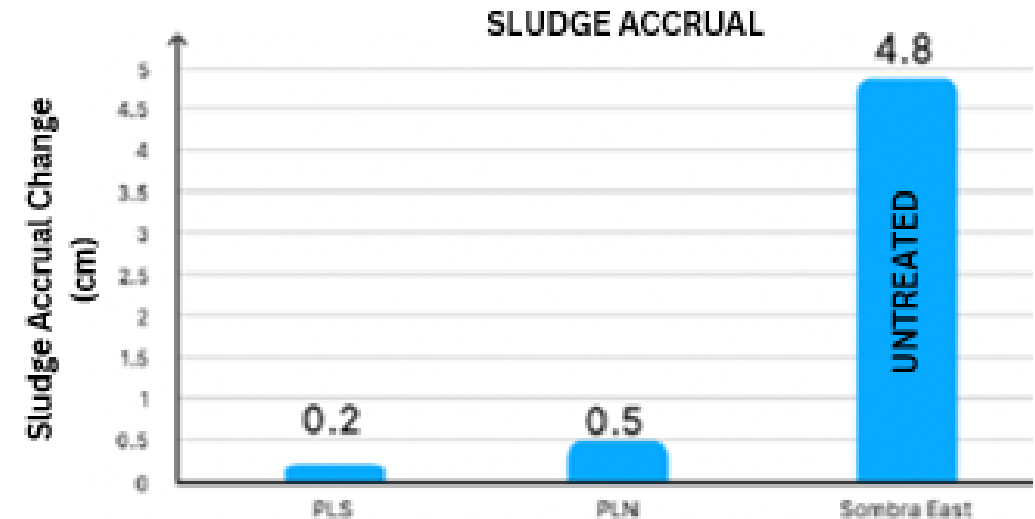

Managing Methane Emission from Sewage Lagoons (IPCC estimates)



Lambton North =
Treated (T)



Lambton South =
Treated (T)



Sombra East =
Untreated (UT)



Conclusions

- Stimulating quantum states of water molecules to change physicochemical properties of a large waterbody without enthalpy changes
- **Cost-effective oxygenation** of large waterbodies to **suppress**
 - mass fish kills
 - cyanobacteria blooms and
 - GHG emissions
- Cost-effective process to **manage sludge and expand treatment capacity** of sewage lagoons

Thank you!

Contact Information:



Dr. Kruti Shukla

kshukla@emfluids.com

Dr. David T. Fung

dfung@emfluids.com

Mr. Jakub Horacek

jhoracek@emfluids.com

www.emfluids.com