

Fundamental principles of Electromagnetic Flow Measurement

3rd Edition
by Friedrich Hofmann, Dipl.-Ing.

KROHNE Messtechnik GmbH & Co. KG
Duisburg, 2003

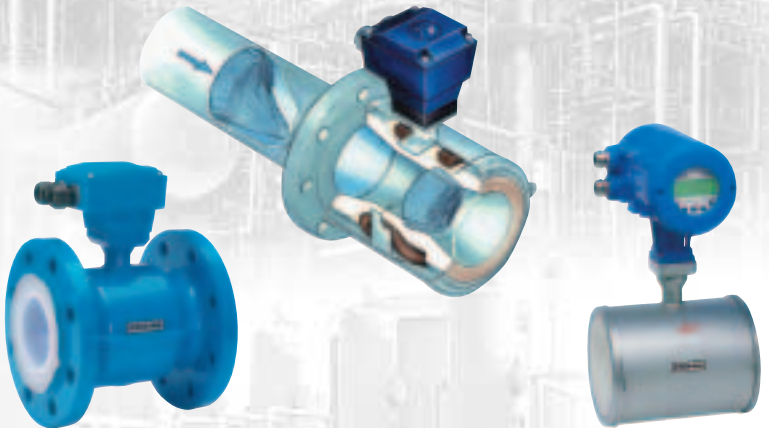



Friedrich Hofmann

Fundamental principles

Electromagnetic Flow Measurement

Table of Contents		Page
1	Electromagnetic flowmeters (EMFs)	6
	Principle and theory, in brief:	6
	Principle	6
	Theory of electromagnetic flow measurement	7
2	Electromagnetic flowmeters (EMFs) for completely filled pipelines	10
	The primary head	10
	The signal converter	13
3	Properties of EMF for completely filled pipelines	17
	Advantages	17
	Limits of application for EMFs	21
	EMFs for completely filled pipelines, fields of application, operating conditions	21
4	Technical versions	25
	Signal generation and processing	25
	Two-wire and multiwire EMFs	29
	EMF models	33
	With remote and integral signal converters	36
5	Selection of device, planning, projecting, installation	39
	Selection of device for completely filled pipelines	39
	Selection of materials for wetted parts	40
	Selection of model	44
	Installation location of the signal converter (electronic unit)	48
	Grounding of the EMF	49
	Installation	51
6	Special versions for special applications	52
	EMFs for partially filled pipelines	52
	Fast volumetric filling applications using EMFs	54
	Electromagnetic flow probes	56

Table of Contents	Page
7 Applications with special requirements	58
Use in hazardous areas	58
Custody transfer	58
Measurement of pulsating flows	58
Use in areas with strong magnetic fields	59
8 Maintenance and testing of EMFs	59
Maintenance-free? Basically yes!	59
Accuracy testing by calibration on an accredited test rig	61
Testing and documentation using intelligent test equipment	61
9 Proven technology of EMFs	63
10 Necessary details for suppliers	66
Process liquid	66
Operating conditions	66
Device type: primary head / signal converter	66
Reference to special operating conditions	67
Setting data, e.g.:	67
Additional requirements	67
Standards relating to electromagnetic flowmeters and the testing thereof	67
11 Bibliography	68
12 List of illustrations	70

Electromagnetic flowmeters (EMFs)

Friedrich Hofmann, Dipl.-Ing., D-47058 Duisburg

Principle and theory, in brief:

Principle

The figure shows the basic setup of an electromagnetic flowmeter (EMF) for completely filled pipelines.

Principle of the electromagnetic flowmeter (EMF)

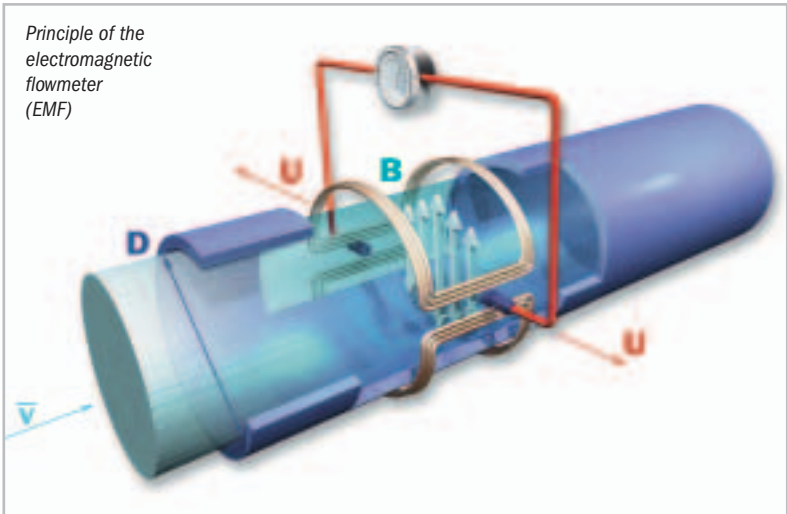

The EMF consists of a non-ferromagnetic measuring tube with an electrically insulating inner surface, and magnetic coils and electrodes that are arranged diametrically on the tube and are in contact with the process liquid through the tube wall.

The field coils through which current flows generate a magnetic field with induction B perpendicular to the longitudinal axis of the tube.

This magnetic field penetrates the measuring tube and the process liquid flowing through it, which must be electrically conductive.

In accordance with the law of induction, a voltage U_i is induced in the process liquid that is proportional to the flow velocity \bar{v} of the process liquid, induction B and the inside tube diameter D . In simplified form, the following expression is applicable:

$$U_i = k \cdot B \cdot D \cdot \bar{v}$$

This signal voltage U_i is picked up by electrodes that are in conductive contact with the process liquid and insulated from the tube wall. Using

$$q = \bar{v} \cdot \pi \cdot D^2 / 4$$

the signal voltage U_i is converted by a signal converter into a flow indication q_i

$$q_i = U_i \cdot \frac{\pi \cdot D}{4 \cdot k \cdot B}$$

and converted into standardized signals appropriate to the process.

Theory of electromagnetic flow measurement

Faraday [1] propounded his law of induction in 1832. This law describes the voltage U_i induced in an electrically conductive body while passing through a magnetic field:

$$U_i = (\mathbf{v} \times \mathbf{B}) \cdot \mathbf{L}$$

where: \vec{U}_i = induced voltage (vector)

\vec{B} = induction (vector)

L = length of conductor moving through a magnetic field, and

\vec{v} = its velocity (vector)

Faraday attempted to determine the flow velocity of the River Thames in 1832 by measuring the voltage induced in flowing water by the earth's magnetic field.

Thürlemann [2], Shercliff [3] investigated the properties of electromagnetic flowmeters. For a theoretical model with an infinitely long homogeneous magnetic field and point electrodes, it was established that the measuring voltage is independent of the flow profile in the measuring tube provided the flow profile is radially symmetrical.

On these assumptions, we obtain the flow-proportional signal voltage U_i as:

$$U_i = k \cdot B \cdot D \cdot \bar{v}$$

where: U_i = induced flow-proportional signal voltage
 k = non-dimensional constant
 B = induction
 D = electrode spacing (measuring tube to inside diameter)
 \bar{v} = mean velocity of the process liquid

Shercliff recognized that the contribution of the finite elements of flow in the measuring tube towards the total signal voltage is weighted as a factor of their location in the measuring tube, and created the term valence vector. Proceeding from Maxwell's equations, he showed that the following applies to the electrode signal voltage U :

$$U_i = \int_{x, y, z} (\vec{W} \times \vec{B}) \cdot \bar{v} \, dx \, dy \, dz$$

(volume integral over the area of the measuring tube permeated by the magnetic field).

The weighing function (vector \vec{W}) determines the contribution of the finite elements of flow towards the signal voltage as a function of their location in the measuring tube. The following figure shows the components of the weighing function in the direction of the electrode axis.

Weighing function of Shercliff's EMF model

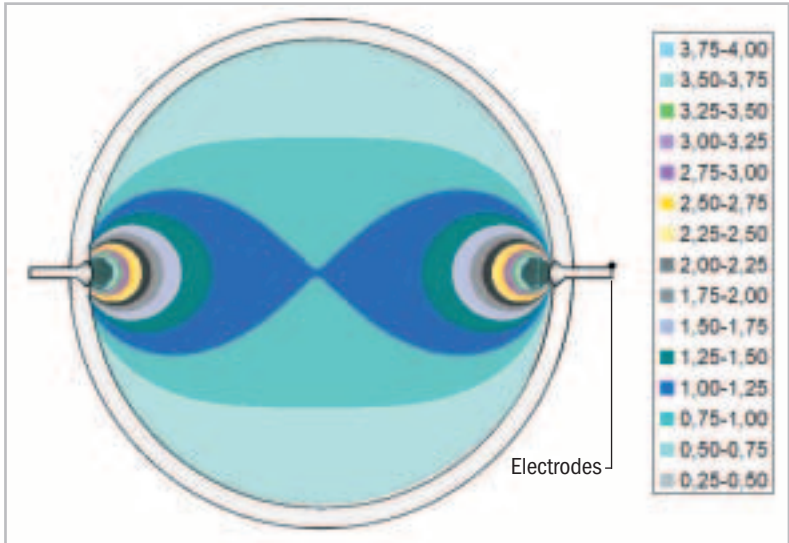

The distinctly recognizable higher sensitivity close to the electrodes results from specific assumptions for this theoretical model. Investigations into inhomogeneous magnetic field forms with the object of reducing the effect of asymmetrical flow profiles on the measuring accuracy of the EMF are to be found, for instance, in [4], [6], [8], [11]. A detailed overview of the theory of the electromagnetic flowmeter and practical versions is given in [5].

Component of weighing vector W in the direction of the electrode axis (Shercliff)

Electromagnetic flowmeters (EMFs) for completely filled pipelines

The primary head

The EMF measuring tube

The magnetic field has to permeate the process liquid through the tube wall, and for that reason the measuring tube should not have ferromagnetic properties.

View into the measuring tube of an EMF (example: tube with Teflon®-PFA liner and Hastelloy electrodes)

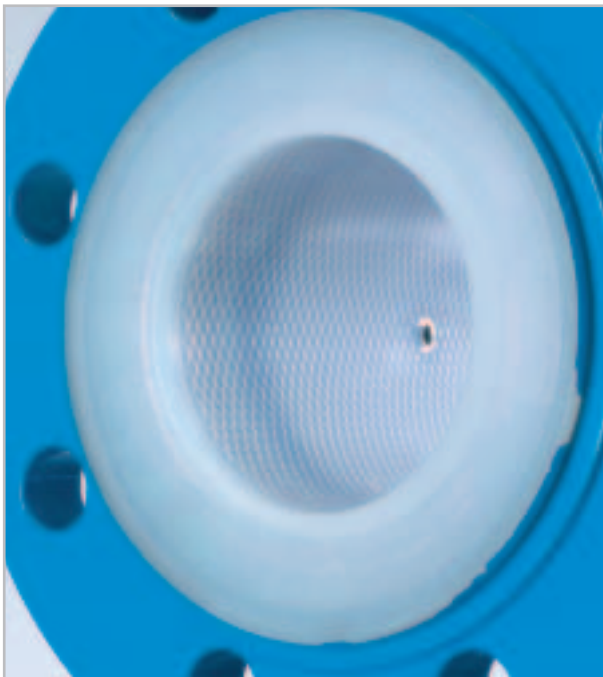

The signal voltage induced in the process liquid should not be short-circuited by electrically conductive tube walls. The measuring tubes are therefore made of an electrically insulating material, such

as ceramics or plastics, or consist of a metal pipe, e.g. non-ferromagnetic stainless steel, with an electrically insulating liner or internal coating.

The inside wall of the tube is in contact with the medium, so the material must have adequate resistance to corrosion.

An overview of the properties of various measuring tube materials is given in the table on page 41.

Electrodes, signal pick-ups

The electrodes are in direct contact with the process liquid. Their material needs to be adequately resistant to corrosion and must allow good electrical contact with the process liquid. The most commonly used electrode materials are stainless steel grades, CrNi alloys, and also platinum, tantalum, titanium zirconium; for primary heads with ceramic measuring tubes also fused-in-place "CERMET" electrodes (mix of CERamics and METal). The right choice of material (not only chemically resistant but also providing good electrical contact with the process liquid) can be decisive for proper functioning of the EMF.

No-electrode EMF with capacitive signal pick-up

For process liquids with extremely low electrical conductivity or those that tend to form insulating deposits on the tube wall and thus interrupt the contact between process liquid and electrode, EMFs are available with a non-contacting capacitive signal pick-up [10], [13].

Here, the electrodes are designed as large-area capacitor plates that are fitted to the outside of the liner or the non-conductive measuring tube. The figure shows the schematic diagram of an EMF with capacitive signal pick-up, in which using methods of microsystem technology the signal pick-ups are rigidly fused with no piezoelectric effect to the aluminium oxide measuring tube.

*CAPAFLUX EMF with
capacitive signal
pick-up and
 Al_2O_3 ceramics
measuring tube)*

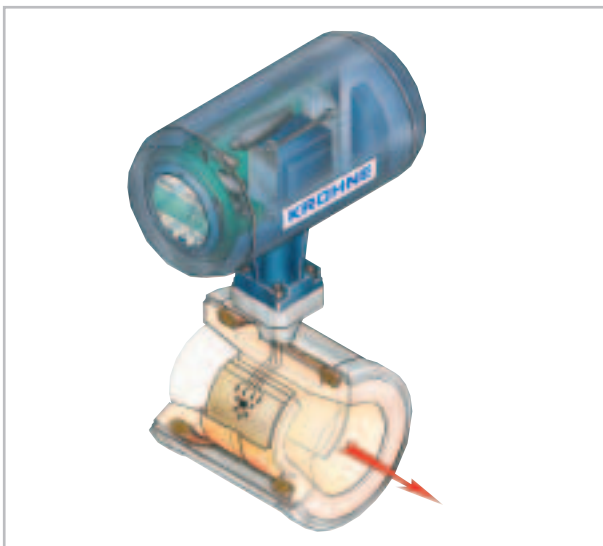

These large-area non-contacting signal pick-ups offer various advantages over the classic wetted electrodes:

- Minimum conductivity of the process liquid can be as low as 0.05 $\mu\text{S}/\text{cm}$ (but it is advisable to clarify with the EMF manufacturers if the medium has a conductivity of less than 0.3 $\mu\text{S}/\text{cm}$)
- No failure of measuring process when non-conductive coatings build up on the inside wall of the measuring tube
- No need to worry about chemical compatibility of the electrode material and the process liquid
- Steadier flow indication also with inhomogeneous media (e.g. with high solids contents or when EMF is located downstream of chemical injection points)

Due to their design, some models of these EMF with non-contacting signal pick-up have a restricted resistance to vibration. Read the manufacturer's specifications thoroughly, and ask again in case of doubt.

Field coils

The field coils that are fitted diametrically to the tube and perpendicular to the electrode axis are normally supplied by the signal converter with a constant current source to generate the magnetic field. The shape of the magnetic field (spatial distribution of induction in the measuring tube) influences linearity and flow profile dependence of the EMF readings. The field coils are located and protected in the EMF housing.

The signal converter

The signal voltage, between μV and mV depending on the flowrate, is forwarded to a signal converter. Its job is primarily to convert the induced signal voltage U into a standard electrical signal.

This includes:

- Amplification of the signal voltage. The input amplifier of the signal converter must be of the very high-impedance type so that the internal resistance of the electrode circuit has no influence on measuring accuracy.
- Conversion of the amplified signal voltage into digital values.
- Filtering of the signal voltage, elimination of superimposed interference voltages, which may be exponentially higher than the flow-proportional signal voltage. Complex digital signal processing methods are in part used for this.
- Scaling the output signals in accordance with the entered operating parameters (full-scale range, meter size of the primary head, span of the mA output, etc.)
- Conversion of the scaled digital values into standard signals suitable for the process (e.g. 4 ... 20 mA, pulses scaled in volumetric units for volume flow counting, or also digital values directly transferable via computer interfaces to process control systems).
- Output of such values
- Indication of flowrate, volume flow counting in the local display
- In the case of EMFs with pulsed dc field, the signal converter also has the function of a precision power supply unit, providing current for generation of the magnetic field with the field coils of the primary head.

The figure below shows these functions by way of a sketch of an existent signal converter.

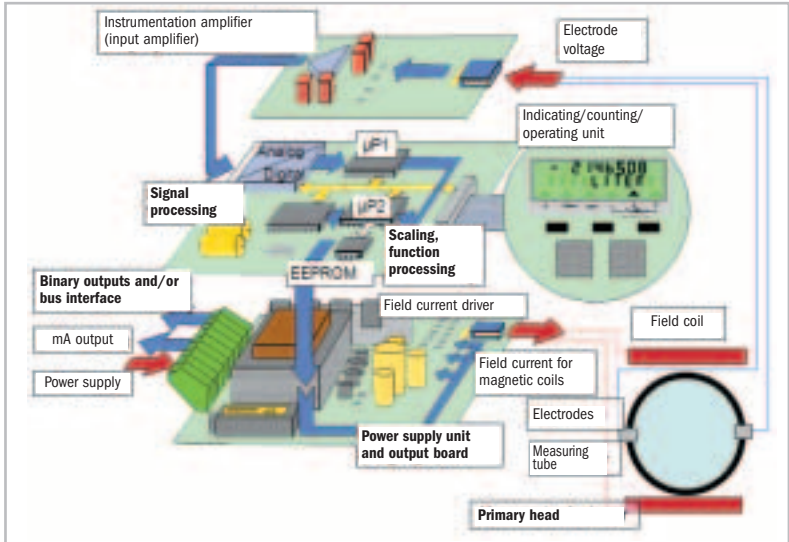

*Functional units
in a μP EMF signal
converter*

EMF signal converters with an internal device bus (e.g. IMoCom = **I**nternal **M**odular **C**ommunication) have been available since 1995 (see figure below).

Internal bus architecture (IMoCom) of the KROHNE μ P EMF signal converter IFC 110

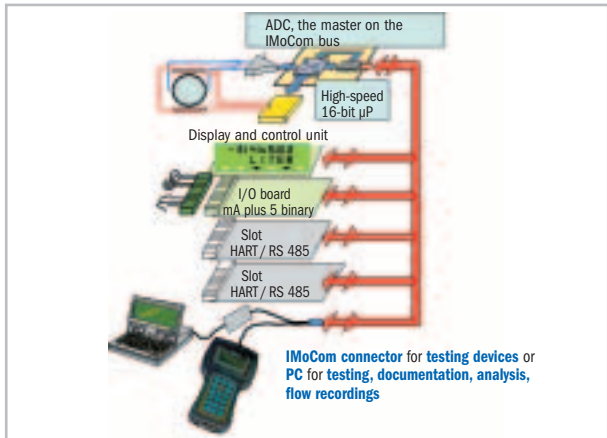

After conversion into digital values, the induced signal voltage is digitally filtered by the first μ P, scaled in accordance with the programmed operating parameters, and transferred to various output units by way of an internal device bus. These include the local display and operating unit, analog (mA) and binary output stages, digital interfaces such as HART, RS 485, Profibus, or also the interface of the internal device bus itself. When connected to a PC or to special intelligent testing devices, this allows testing and documentation of the accuracy, functionality and integrity of the set operating parameters.

With the aid of the PC, the flow over time can also be oscillographed online via this interface, stored and later evaluated by using a spreadsheet program (see figure). This allows e.g. statements to be made about flow behaviour, the closing response of valves, the quality factor, and the correct functioning of pulsation dampers.

Properties of the EMF for completely filled pipelines

Advantages

Free pipe cross-sectional area

- No additional pressure drop: can therefore be used for gravity feed applications, e.g. in wastewater technology, even with slightly descending gradients without increasing backpressure and saves energy (no additional pumping capacity necessary)
- Allows measurement of media with high solids content (e.g. ore or dredging slurries), no risk of plugging, minimum risk of abrasion
- The size of the EMF is usually the same as the nominal diameter of the process piping!



No mechanically moving parts

- The EMF is therefore practically wear-free, has an extremely long service life, and is proof against overload
- Extremely high turndown ratio: the EMF can therefore measure right down to the lowest flow velocities (down to zero). For specific applications, however, a starting threshold can be set in the signal converter ("low-flow cutoff"), e.g. to rule out the effect of thermally induced residual flows on volume flow counting during downtimes).

High accuracy even in difficult operating conditions

Because of the linear measuring principle used, EMFs exhibit only minor variations (less than 0.2% of the measured value at reference conditions), high linearity and wide measuring spans (over 1:100 at errors of less than 1% of the measured value).

Typical limits of error at reference conditions

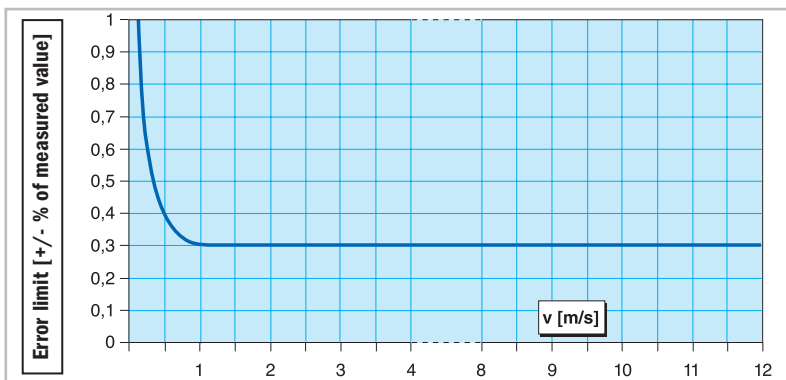

Linear measuring principle

The linear interrelationship between flow velocity v (flowrate q) and signal voltage U allows for precise linear signal processing and hence simple and wide setting of the measuring ranges as well as accurate measurement of pulsating flows.

Largely independent of viscosity and density

When flow transits from turbulent to laminar (or vice versa), minor variations in measurement accuracy may occur, depending on the design of the primary head.

Largely independent of the flow profile: short inlet runs!

The measurement results in the following figure show that disturbed flow profiles only have a minor effect on the measuring accuracy of EMFs. The diagram shows that, with the same inside diameter of EMF and pipeline, a straight unimpeded inlet run of only $5 \times D$ (D = inside diameter) will assure high measuring accuracy. In isolated cases, this "short" inlet run (albeit as much as 5 m for DN 1000!) will cause construction problems. In such cases, for example, the inlet run can be shortened by up to a factor of approx. 2 by using concentric reducers and a slightly smaller sized EMF, but a slight additional pressure drop will then occur.

*Flow profile
influence, EMF*

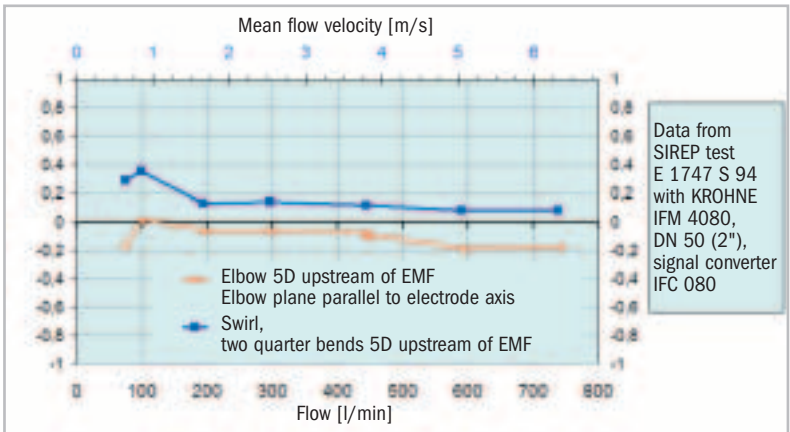

Measurement in both directions of flow

The EMF can measure flow in both directions with equal accuracy (provided that sufficiently long unimpeded inlet runs are provided on both sides).

*Pulsating flow
(170 strokes/min)
at the outlet of a
diaphragm pump.
Measured with
KROHNE
EMF IFC 110 with
pulsed dc field*

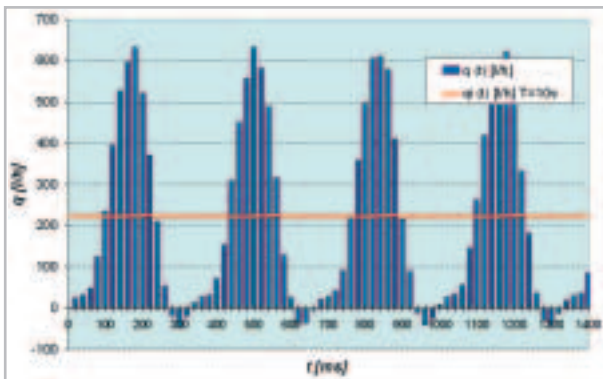

Measurement of pulsating flow

Only very few flowmeters are capable of measuring pulsating flows without the use of pulsation dampers at the outlet of positive-displacement pumps. **EMFs have been applied with excellent results in these difficult flow applications.**

The figure shows the digitized flow values on the internal device bus (IMoCom) in the KROHNE signal converter IFC 110 behind the first digital filter.

However, not every EMF type from every supplier can do this, and possibly special settings will be necessary. On this issue the suppliers should be consulted first (before placing the order!)

The liner provides chemical resistance

Selection of the correct liner material will provide outstanding protection against corrosion, even where highly aggressive media are involved.

Limits of application for EMFs

Minimum conductivity

The process liquid needs to have a specific minimum electrical conductivity.

The manufacturers' details for this minimum conductivity level range from 0.05 - 50 $\mu\text{S}/\text{cm}$, depending on version, process liquid and application. Hence, EMFs are not suitable for the flow measurement of hydrocarbons (gasoline, oil, etc.) or gases.

Process measurement problems can occur (measuring errors, unsteady readings) below the specified minimum conductivity. Higher conductivity levels do not affect the properties of the EMF.

EMFs for completely filled pipelines, fields of application, operating conditions

Meter sizes, diameters

EMFs are available in meter sizes from DN 1/0.04" (inside diameter approx. 1 mm/0.04") to DN 3000/120" (3 m/120" inside diameter). Hence flow-rates can be measured accurately from approx. 1 l/h to far above 100 000 m^3/h /400 000 USGPM.

Pressure ratings

Nominal pressures possible up to 1500/22000 psig bar and more.

Process temperature

The maximum temperature is, above all, dependent on the material of the liner; typical manufacturers' details for PTFE or PFA liners and ceramic measuring tubes: up to 180°C/356°F; special versions with ceramic measuring tube: up to 250°C/482°F.

Explosion protected versions

Suitably approved "Ex" versions are available for use in hazardous areas.

For custody transfer purposes

Device versions with appropriate approvals are available for the volumetric measurement of cold water, liquids except for water, and for flowmetering in connection with measurement of thermal energy.

Type of protection

Up to IP 68/NEMA 6P (continuous submersion)

Common products in various industries, examples

Food industry:	milk, liquid dough, liquid egg, ice-cream, ketchup, yogurt,
Beverage industry:	beer, lemonades, wine, fruit juices, fruit mixes,
Chemical industry:	acids, alkalis, suspensions,
Water supply:	raw water, potable water, chlorine dioxide solution, flocculants,
Wastewater treatment:	raw wastewater, sludges up to 30% dry solids
Energy supplies:	gypsum suspension in flue gas desulphurization systems, cooling water, measurement of thermal energy,
Ore preparation, mining:	ore slurries, drilling fluids,
Building industry:	plaster, floor topping, concrete,
Paper and pulp:	high-consistency pulps, papermaking stock, filling material, bleaching agents, screenings.

Process liquids: what needs to be considered?

Minimum electrical conductivity

Typical manufacturers' specs: 5 $\mu\text{S}/\text{cm}$.

0.05 - 50 $\mu\text{S}/\text{cm}$ are possible, depending on device version, process liquid and application. Down to 0.05 $\mu\text{S}/\text{cm}$ with EMFs with non-contacting capacitive signal pick-up.

Homogeneity of the process liquid

Poorly mixed media with unevenly distributed electrical conductivity can cause measuring errors. Also, incomplete chemical reactions (and the electrochemical processes involved) can cause interference voltages in the process liquid and at the measuring electrodes, and can thus cause unsteady indication. For that reason, the EMF should be installed upstream of mixing, injecting and neutralizing points.

Solids in the process liquid

Because of its free tube cross-sectional area and the fact that the magnetic field can propagate without disturbance through solids, the EMF is the ideal flowmeter for hydraulic transport purposes.

For example, EMFs are used on dredging vessels to measure slurries with solids contents of approx. 50% and 'particle' sizes of up to 50 cm at flow velocities of approx. 15 m/s.

The following points should be noted when using EMFs in the hydraulic transport of abrasive solids:

- The material of the measuring tube needs to be adequately resistant to abrasion.
- The flow velocity should be high enough to avoid deposits but not so high as to irreparably damage the measuring tube too quickly.
- The ideal solution in this case would be to install the EMF in a vertical pipe run (ascending pipe).

Entrained solids can strike the electrodes, thus possibly leading to unsteady readings. Special EMF versions are available for media with high solids contents. Inform the manufacturer about such an application in the design phase.

Entrained gas

The EMF is a volumetric flowmeter. Any gas dispersed in the liquid is measured as volume, and the total volume is displayed. Because gas entrainment is usually unintentional and only the volumetric flowrate of the liquid phase is to be determined, the displayed data appear to be too high (almost all flowmeters exhibit this performance). In addition, the display may be unsteady.

Such effects can be avoided by using gas separators, by locating drainage points from storage vessels at a suitably low point, and by installing the EMF on the delivery side of pumps (not the suction side!).

The entrained gas is compressed on the pump delivery side, so the real volumetric proportion of the gas and the variations between measured total volume (including gas) and actually transported volume of liquid become very small. When installed on the suction side of the pump, the pressure is low (down to vacuum), the gas volume becomes very large, and the indication error is accordingly higher.

Technical versions

Signal generation and processing

The EMF electrode voltage

The flow-proportional signal voltage at the electrodes amounts to a few mV, possibly even only a few μV when flow is very low. The available power of this signalling circuit is some 10^{-18}W to 10^{-12}W . For reliable and interference-free generation and transmission of such small signals, special measures are required such as shielding of the signal cable and grounding of the primary head.

The flow-proportional signal voltage is superimposed by electrochemical interference dc voltages that are formed at the interface between electrodes and process liquid. These interference voltages can be 100 mV and more, and are exponentially greater than the flow-proportional signal voltage to be evaluated. Additionally, line-frequency interference voltages will often be superimposed on the signal voltage.

Time characteristic of the magnetic field

An easy way to distinguish between this interference dc voltage and the signal voltage is to deliberately vary the signal voltage over time by modulating the induction, i.e. of the field current in the coils of the primary head. At induction $B = 0$, the signal voltage $U = 0$. If the field current through the coils is increased, then this increases induction B and hence signal voltage U accordingly. When the coil current is reversed, i.e. B is inverted, U will likewise reverse the sign. This effect is exploited in various forms for EMFs to discriminate between the signal voltage and the electrochemical interference dc voltage.

The EMF with sinusoidal ac field

The first industrial EMFs had field coils simply connected to the line ac voltage. The line-frequency sinusoidal field current generates a line-frequency sinusoidal magnetic field

$$B(t) = \vec{B} \cdot \sin(\omega \cdot t) \quad \text{and accordingly an induced signal voltage}$$

$$U_i(t) = k \cdot D \cdot \vec{v} \cdot \vec{B} \cdot \sin(\omega \cdot t)$$

This signal ac voltage is easy to distinguish from the electrochemical dc voltage and can be further processed without being affected by it. The following side-effects occurred with this ac field EMF, and have probably never managed to be entirely eliminated:

- Line-frequency external parasitic via the pipeline and process liquid (e.g. insulation fault currents, e.g. from pump drives), or from potential differences and internal interference between field coils (230 V, power consumption up to the kVA level) and the signalling circuit generate line-frequency interference voltages in the process liquid and at the electrodes of the EMF.
- The signal converter cannot fully discriminate these line-frequency interference voltages and the line-frequency signal voltage, because they have the same frequency and waveform as the induced signal voltage. Therefore, these interference voltages lead to falsification of the display.
- The setting of the display zero point must therefore be checked at frequent intervals. This can only be done when the process liquid is non-flowing, for which the pipeline needs to be shut off. The necessary shutoff elements cause high measuring-point costs, maintenance outlay is high and often difficult to reconcile with operational requirements.

AC-field EMFs are virtually no longer installed in new plants today and have been almost entirely replaced by EMFs with pulsed dc field.

The EMF with pulsed dc field

The field coils of the primary head are supplied with a precisely controlled constant current that has an approximately trapezoidal waveform.

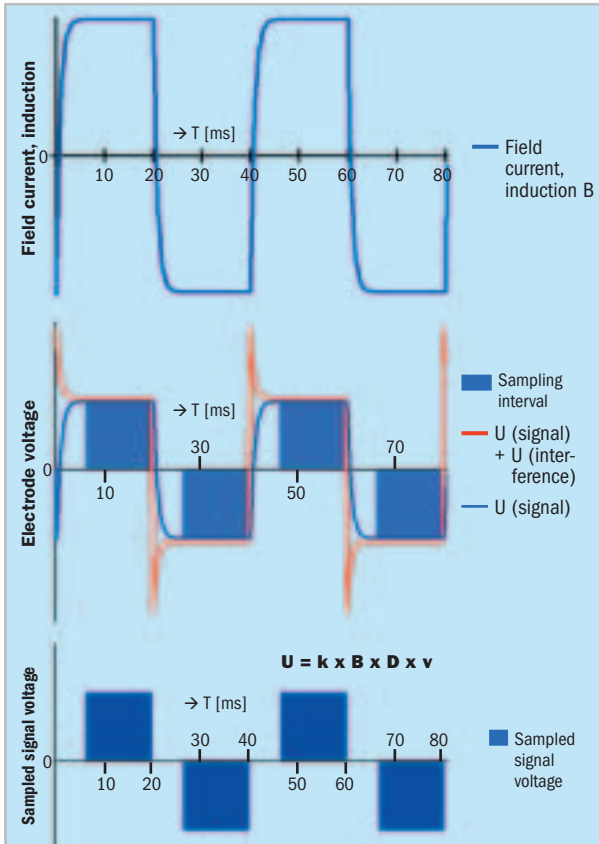

Typical time characteristic of field current and electrode voltage in an EMF with pulsed dc field

The induced interference voltages occurring briefly due to change-over of the field current can be clearly seen. But the signal converter does not accept the electrode voltage until these interference voltage peaks have died down sufficiently. That is the case when field current, and thus induction, are constant (as in the case of a dc field, e.g. of a permanent magnet)

$$(U_{tr} = A \cdot dB / dt = 0).$$

So the influence of these interference voltages on measuring accuracy is reliably eliminated.

Line-frequency interference voltages are easy to suppress because the field and signal frequencies of EMFs with pulsed dc field have been defined as deliberately deviating from the line frequency. The signal processing system can therefore readily distinguish between line-frequency interference and the signal voltage. Further details are described e.g. in [7]. The electrochemical interference dc voltage can be suppressed by using a high-pass capacitor coupling or by calculating the difference between a succession of sampled values or by using more complex techniques such as the interpolation method introduced by KROHNE in 1973.

This completely eliminated the weak points of the EMF with ac field. Thanks to the pulsed dc field (introduced in 1973), the EMF has developed into a rugged and maintenance-free measuring device of high accuracy.

Two-wire and multiwire EMFs

Briefly, the basic difference between two-wire and multiwire flow-meters is:

Multiwire meters have a power connection via which they can be supplied from a separate power source with any power needed (e.g. 20 W).

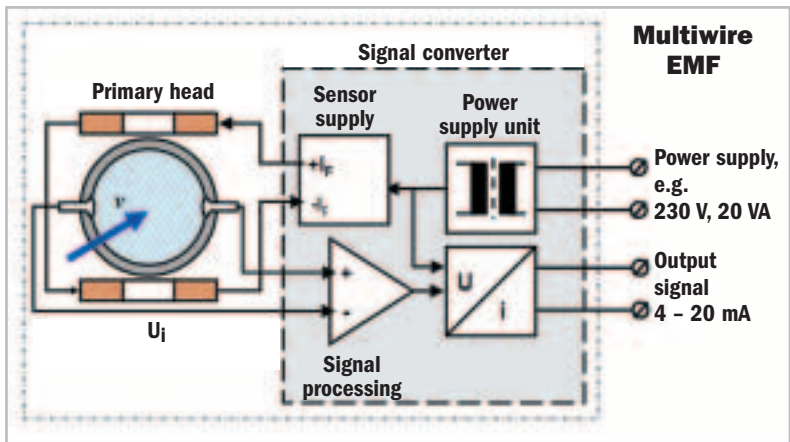

Classic multiwire EMFs

Multiwire EMFs have a separate power connection which allows "unlimited" power input (see figure above). They usually have quite user-friendly output options, e.g. a number of active outputs, which feed a passive mA indicator (e.g. the classic moving-coil instrument) without additional power for such output, or with current or voltage pulses can also actuate totalizers.

Typically, these EMFs power the field coils with approx. 0.4 – 1.5 W (for special applications even approx. 15 W). That creates strong magnetic fields and hence relatively high signal voltage levels. Interference voltage such as varying electrochemical voltages in inhomogeneous media or chemical reactions that are still in progress, noise due to low conductivity or solids and entrained gas in the medium, electrical interference from the surroundings can be reliably suppressed by standard (including digital) signal processing methods.

Two-wire EMF

Two-wire EMFs arose from the wish for simple and low-cost cabling, as has long been used, for example, for differential-pressure sensors in orifice plates.

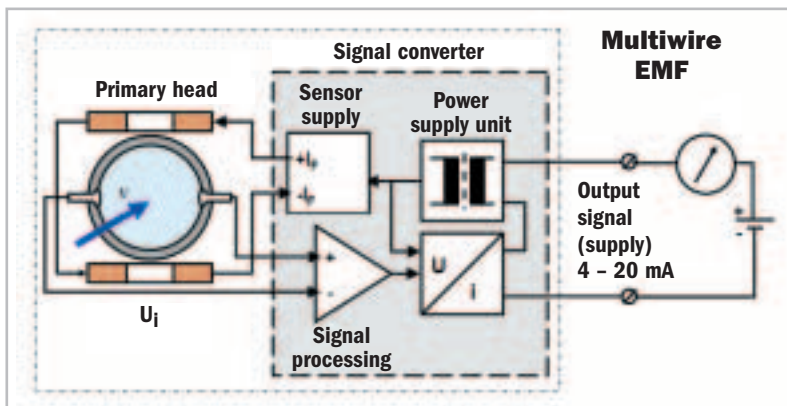

For EMFs, this requirement was much more difficult to meet, even if the principle of the two-wire EMF has a striking resemblance to that of the multiwire EMF. It is the little things that always cause the problems, and in this case it was just one small detail:

With an auxiliary voltage of e.g. 15 V, the two-wire 4 – 20 mA connection only makes some 0.06 – 0.3 W available.

Even if at a low flow rate approx. 0.04W (i.e. almost 70%) is available for supplying the sensor and thus for generating the measuring signal, it is still lower by a factor of 10 – 40 as compared to the multiwire EMFs.

This drawback greatly restricted the range of application of earlier two-wire EMFs. A clear indication of this is that 50 $\mu\text{S}/\text{cm}$ were specified as being the minimum allowed conductivity of the medium.

Modern two-wire EMFs offer the same application limit of 5 $\mu\text{S}/\text{cm}$ as standard EMFs.

This has been achieved by using ultramodern electronic components, new digital filtering techniques for suppression of noise, and by innovative methods such as an intelligent power unit that utilizes all available energy optimally for sensor supply and thus for large noise-free signals [16].

Despite the low power available to the sensor, modern two-wire EMFs have an outstanding signal-to-noise ratio, and accordingly can be used for the full application range of the standard EMF down to 5 $\mu\text{S}/\text{cm}$.

For extremely difficult applications, additional application-specific digital filters can be activated via the operator menu in order to blank out noise.



*Two-wire EMF
ALTOFLUX 2W
from KROHNE,
flanged design*

Major benefits of the two-wire EMF

- Simple, low-cost cabling (according to the chemical industry, potential savings of approx. 1800.- € per measuring point as compared to multiwire EMFs)
- Easy to incorporate into "Ex" concepts:
with the two-wire EMF from KROHNE the user can, thanks to the flexible "Ex" concept, select freely between the "i", "e" and "d" types of protection.
- Simple integration into systems with intrinsically safe "Ex" concept.
- Easy upgrading of measuring points with conventional mechanical or differential-pressure based flowmeters by EMFs, without the need to change existing cabling.
- Low operating costs (cost of ownership):
practically maintenance-free, extensive diagnostic functions, low power consumption, etc.
- High measuring accuracy:
0.5% of measured value at $v > 1$ m/s.
- Modern two-wire EMFs can be used for almost all EMF application ranges with comparable performance but with lower installation costs than four-wire EMFs.

EMF models

Primary head models according to process connections

Flanged version

This version is fitted with flanges (different pressure ratings, national standards such as DIN, ANSI, ISO, JIS) for connection to the process line.



Flanged version of the EMF primary head, ALTOFLUX DN 3000 mm, measuring range 0 ... 100.000 m³/h; 0 ... 400.000 USGPM

Typical liner materials are hard rubber, soft rubber, fluorine-based plastics such as Teflon® PTFE or Teflon® PFA, or ETFE (TEFZEL®). Additionally, irathane (special PU) for highly abrasive process liquids.

Sandwich (or wafer) version

The 'sandwich' or 'wafer' version is clamped with tie bolts between the flanges of the pipeline. This version is available with a choice of liners (hard rubber, fluorine-based plastics, and ceramics).

Sandwich EMFs with high-density aluminium or zirconium oxide ceramic measuring tubes have a particularly high measuring accuracy and long-time stability, also at high process temperatures, owing to the dimensional stability and low thermal expansion coefficient of this material.

In addition, the KROHNE EMF 5000 shown below with built-in conical reducer smooths highly distorted flow profiles and so reduces measuring errors in unfavourable installation conditions.

*Sandwich EMF
KROHNE
PROFIFLUX 5000
with flow-optimizing
measuring tube of
 Al_2O_3 ceramics*

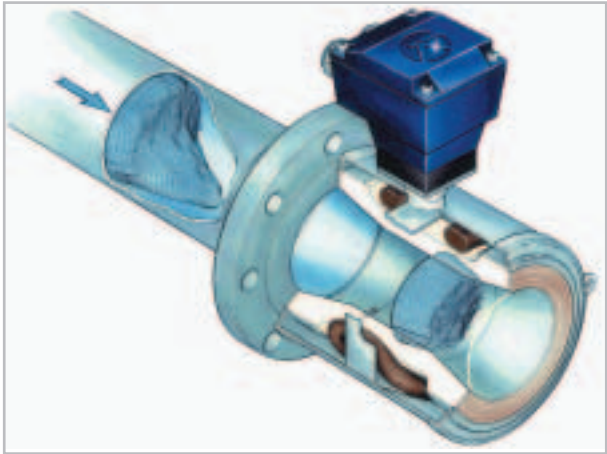

Sanitary versions

In the food and beverage industry and the pharmaceutical industry, all fittings must allow cleaning and sterilization (CIP) by chemical processes and by superheated steam (SIP). In addition, there should be no gaps, crevices or blind spots in which bacteria can lodge. For that reason, special sealing methods are used (e.g. as shown in the following figure), L-shaped gaskets with trapezoidal sealing lip that were developed and tested in cooperation with institutes of hygiene such as EHEDG.



VARIFLUX 6000 compact design. Crevice-free seal between lined measuring tube and process pipe or adapter using L-shaped gasket with trapezoidal sealing lip

The materials used should not give off any impurities to the medium (are required to be food-compatible, e.g. FDA-approved). PTFE or PFA is normally used for the liner. Process connections are available that meet the requirements of the most varied standards, e.g. dairy screw connections, clamps, sanitary flanges, etc. or also welded joints. Adapters for these connections are of the modular type and can be bolted simply, reliably and hygienically to the EMF shown.

EMFs with remote and integral signal converters

Separate-system version (with remote converter)

Primary head and signal converter (electronic unit with signal processing, operating and display unit and feeder unit for the field coils) are two separate units, each with their own terminal box.

A shielded signal cable and a field current cable, which transmits the power for the field coils in the primary head, join them.

Primary head for the separate system

The primary head has no moving parts or electronic components. It is therefore particularly rugged, and can easily and for long times withstand high process temperatures, high levels of vibration, water hammer in the pipeline, and ambient humidity (given appropriate type of protection also up to complete submersion).

*Flanged EMF
with remote signal
converter:
ALTOFLUX 4000
with IFC 110*

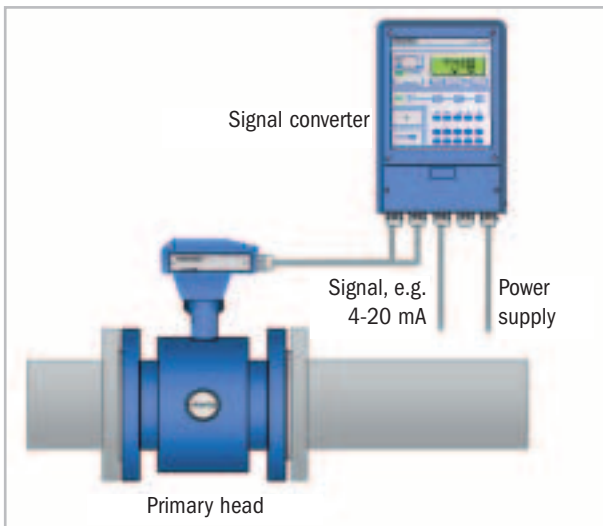

Flanged primary heads, sandwich and sanitary versions are available as separate-system units (i.e. with remote signal converter).

Remote signal converter

Signal converters as separate units can be installed in readily accessible points that are protected against flooding, direct sunlight and any high pipeline temperatures. Vibration from the pipeline is not transmitted. Therefore signal converters of separate-system design have maximum reliability.

Signal cable for separate-system EMFs

The low signal voltage U (millivolts, picowatts) must be transmitted via a shielded signal cable from the primary head to the signal converter, for which the EMF manufacturers offer special shielded cables. Some manufacturers fit an extra magnetic shield to these cables as protection against interference from external magnetic fields. The cable types recommended by the EMF suppliers should be used for reasons of electromagnetic compatibility and operational reliability.

*Shielded
KROHNE signal
cable type DS for
separate-system
EMF*

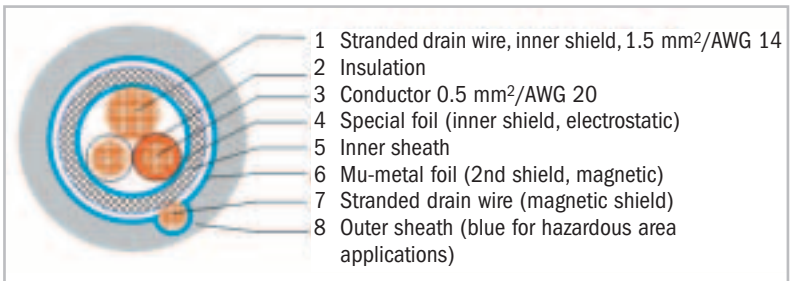

Depending on supplier and type, the length of this signal cable is limited for measurement reasons and also for safety reasons when used in hazardous areas.

EMFs with integrated converter ("compact version")

Configuration

The Figure shows an EMF of compact design. Primary head and signal converter form a single unit which is easy to install and connect up at low cost.

This model saves laying and connection of special shielded signal cables and mounting of a separate signal converter.

Acquisition and installation costs are less than for the separate-system version.

Limits of application

The allowable process temperatures for compact EMFs are lower than for the separate-system version because the process temperature will to a certain extent affect the signal converter. The electronic components would then be subjected to higher temperatures, and their reliability would decrease noticeably. Vibration and water hammer are transmitted direct to the signal converter. For that reason, the pipeline needs to be supported on both sides of the compact EMF.

*Flanged EMF
ALTOFLUX 4080 K,
compact design*

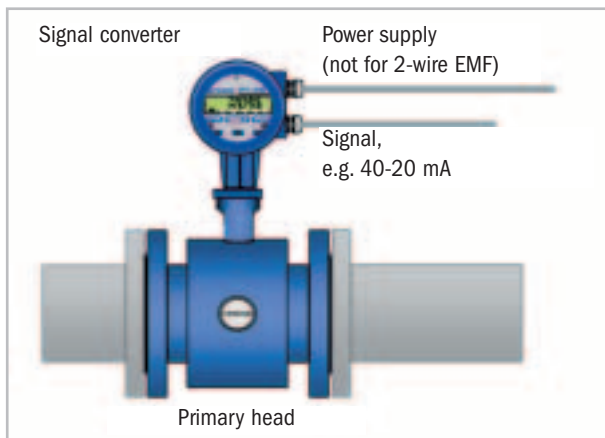

Selection of device, planning, projecting, installation

Selection of device for completely filled pipelines

Selection of meter size

As a general rule, the DN size of the EMF should be equal to the pipeline DN size, never larger!

The full-scale range can be adapted to suit the most varied operating conditions (e.g. to flow velocities from 0.3 to 12 m/s, 1 to 40 ft/s, equivalent to approx. 2.2 - 84 m³/h for DN 50 mm or 580 - 22 190 USG-PM in a 2" meter).

In the following cases the DN size of the EMF should be smaller than the nominal diameter of the pipeline (use of reducers).

*Pipe reducers
upstream and
downstream
of the EMF*

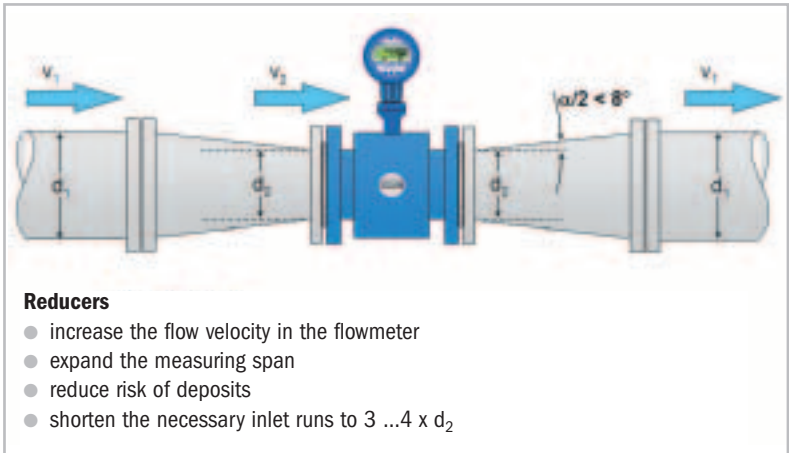

Media containing solids with a tendency to form deposits

Depending on the solids involved: DN size of the EMF to be such that flow velocity v is > 3 m/s, 10 ft/s. A reducer and the higher flow velocity reduce the risk of deposits.

Unfavourable inlet conditions (unimpeded straight inlet run of 5 D cannot be implemented):

Installing a reducer directly in front of the EMF ($\alpha/2 < 8^\circ$) will smooth the flow profile. The smaller inside diameter of the EMF determines the inlet run. With such a reducer, a length of 3 D ($D = DN$ or size of the EMF) will suffice as the inlet run behind an elbow or T-piece without any appreciable loss of accuracy.

Requirement for a very wide measuring span

Rather like when using a yardstick or folding rule, the measuring error of an EMF will increase when used to measure very small quantities. For that reason, the reducer is designed for measurement over wide spans such that, at maximum flowrate, flow velocity v will be e.g. approx. 10 m/s, 33 ft/s.

Example DN 50/2": from approx. 77 m³/h/20300 USGPM down to approx. 0.77 m³/h/203 USGPM, the EMF will then indicate measuring errors of less than 1% of the measured value (depending on type and installation location).

Submersion (type of protection)

If installed in locations with risk of submersion, select IP 68/NEMA 6P type of protection! Lengthy submersion of IP 67/NEMA 4X, 6 devices (or lower protection category) could damage the EMF irreparably.

Selection of materials for wetted parts

Liner and electrodes are in contact with the process liquid. Both have to survive this contact for decades without sustaining damage. The right choice of material has decisive influence on the service life of the measuring device. The incorrect selection ("cost consciousness") may turn out to be very expensive in the long run!

Liner / tube material

Chemical resistance alone is not enough!

Dimensional stability and vacuum resistance, sometimes also the abrasion resistance of the liner, can be equally decisive for the lifetime and long-term stability of an EMF. For an initial rough guide, refer to the following table.

Properties of various measuring tube liner materials

Material	Max. process temperature	Chemical resistance	Abrasion resistance	Permanent deformation under pressure/temperature	Available DN range [mm]	Vacuum resistance
Fluoro-plastics (e.g. PTFE, PFA)	up to 180°C 356°F	from hot alkaline solutions to hot concentrated acids	slight to good, depending on design	pronounced to slight, depending on design	2-600 0.1"-24"	poor to slight, depending on design
PFA with stainless steel reinforcement	up to 180°C 356°F	from hot alkaline solutions to hot concentrated acids	good	slight	2.5-150 0.1"-6"	very good
ETFE ("TEFZEL")	up to 120°C 250°F	from hot alkaline solutions to hot acids	very good	slight	200-600 8"-24"	very good
Hard rubber	up to 90°C 195°F	low concentrations	slight	very slight	25-3000 1"-120"	relatively good
Polypropylene with stainless steel reinforcement	up to 90°C 195°F	low concentrations	good	slight	25-150 1"-6"	very good
Soft rubber Neoprene	up to 60°C 140°F	low concentrations	good	slight	25-3000 1"-120"	relatively good
Polyurethane	up to 60°C 140°F	low concentrations	excellent	slight	50-1600 2"-72"	good
Aluminium/zirconium oxide ceramics	up to 180°C 356°F	from warm alkaline solutions (medium concentrations) to concentrated acids below 100°C	material with maximum abrasion resistance	practically no deformation (high long-time stability also with small meter sizes (DN)	2.5-250 0.1"-10"	absolutely vacuum resistant

If in doubt, the manufacturers will advise.

Selection of electrodes

Selection of material

The most important point is outstanding chemical resistance properties. Selecting a "cheaper" material can result in total failure of the EMF, leakages and damage to the environment.

Equally important for proper functioning is the electrical contact between electrode surface and process liquid. The measuring system will fail if, for example, insulating compounds are deposited on the electrode surface (example: tantalum electrodes and water as the process liquid).

Rough overview (check the chemical resistance for your particular case!)

Hints for selection of electrode material

Process liquid	Proven electrode materials
Water, wastewater	Stainless steel, HC4, platinum, platinum-Cermet
Concentrated oxidizing acids	Tantalum, platinum, platinum-Cermet
Alkalis	Platinum, partially platinum-Cermet

The need to make this selection can be dispensed with if a "no-electrode" EMF with capacitive signal pick-up is used.

With electrodes or without (capacitive)?

No-electrode EMFs are used by preference in the following cases:

- Conductivity < 5 $\mu\text{S}/\text{cm}$ (down to 0.05 $\mu\text{S}/\text{cm}$, discuss application with the manufacturer!)
- Media with a tendency to form deposits and insulate the electrodes from the process liquid in a classic EMF (e.g. latex and bitumen suspensions, etc.)
- Extremely abrasive liquids
- Chemically inhomogeneous media.

Special electrode designs:

Electrodes are not easy to remove from a large EMF. Where 'difficult' media are concerned (e.g. wastewater containing high levels of grease), although it has not happened yet, the possibility that grease will deposit on the electrode cannot be ruled out altogether. Having to dismantle a DN 1600 EMF for that reason is an expensive business and often not even possible.

The answer as a "life assurance" is field replaceable electrodes. Using an isolation valve, they can be dismantled, cleaned and replaced under pressure.

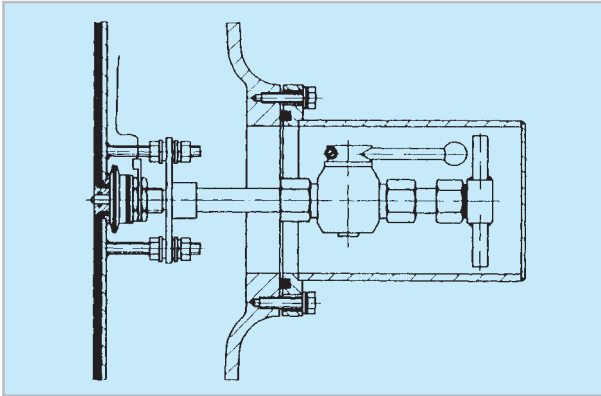

Field replaceable electrode (removable under pressure for cleaning).

Selection of model

Compact or separate-system?

The following table will help you to reach a decision.

A separate-system version should always be selected if, due to the conditions at the measuring point, only one "no" is given as the answer in the "integral converter appropriate?" column.

Selection criteria:

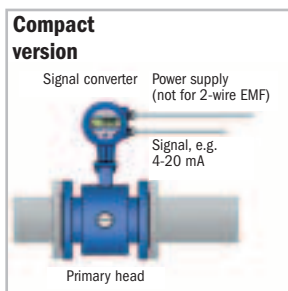
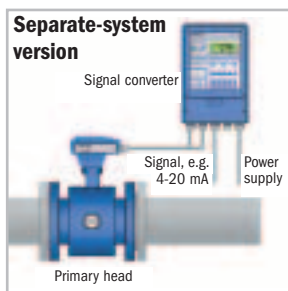

Choice of "compact"/
"separate-system"

Application conditions	Remote converter necessary?	Integral converter appropriate?
High process temperature?	yes	no
High ambient temperature at measuring point?	yes	no
High level of pipeline vibration?	yes	no
Risk of submersion at the measuring point?	yes (IP 68 / NEMA 6P type of protection)	no
Extremely corrosive atmosphere at measuring point?	yes	no
Good accessibility to measuring point?	no	yes
Poor accessibility to measuring point?	yes	no
Numerous functions/outputs necessary?	yes	no
Do costs have highest priority?	no	yes

Flanged or sandwich EMF?

Sandwich EMFs (also called 'wafer' or 'flangeless' devices) are less expensive in price and easier to install at lower cost than flanged devices. Outside mainland Europe, the view is now held that, for very many applications, four flanges per measuring point are an unnecessary expense. Since cost savings are today's number one priority, due consideration should be given in the layout of measuring points to sandwich flowmeters, which in most cases are distinctly less expensive than flanged EMFs.

**Flanged
or
sandwich
EMF?**

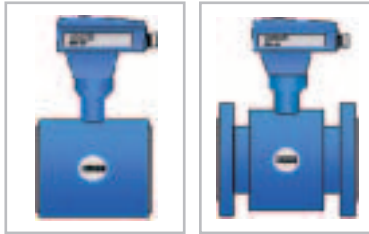

Criteria	Sandwich EMF	Flanged EMF	<i>Selection "flanged"/ "sandwich"</i>
Costs (assuming otherwise same configuration)	more favourable	less favourable	
Weight (installation)	lighter	heavier	
Metrological properties (assuming otherwise same configuration)	equally good	equally good	
Compatible with DIN/ANSI/JIS flanges	all in one version	one version each	
Precision ceramics EMF (small DN sizes especially)	only sandwich version available	not available as flanged device	

Selection of installation location for the primary head (EMF for completely filled pipelines)

The most essential points are briefly addressed here. Details and binding regulations are found in the application guidelines issued by the manufacturers. These manufacturer guidelines should always be consulted first.

Straight unimpeded inlet and outlet runs

Most manufacturers recommend unimpeded inlet runs of 5 x D downstream of elbows and T-pieces.

Control valves or similar to be installed only downstream of the EMF. Reasons: flow profile, vacuum (see below), and risk of vacuum strokes.

The inlet run may be shortened by a factor of approx. 2 (e.g. by installing a reducer, see page 39).

Ensuring the tube is completely full, avoiding a vacuum:

Refer to the following figure.

Installation in horizontal or ascending pipeline:

- The installation position has no effect on functioning or accuracy of the EMF.
- When installed in horizontal pipelines, ensure the electrode axis is always horizontal!

Suggestions for installation

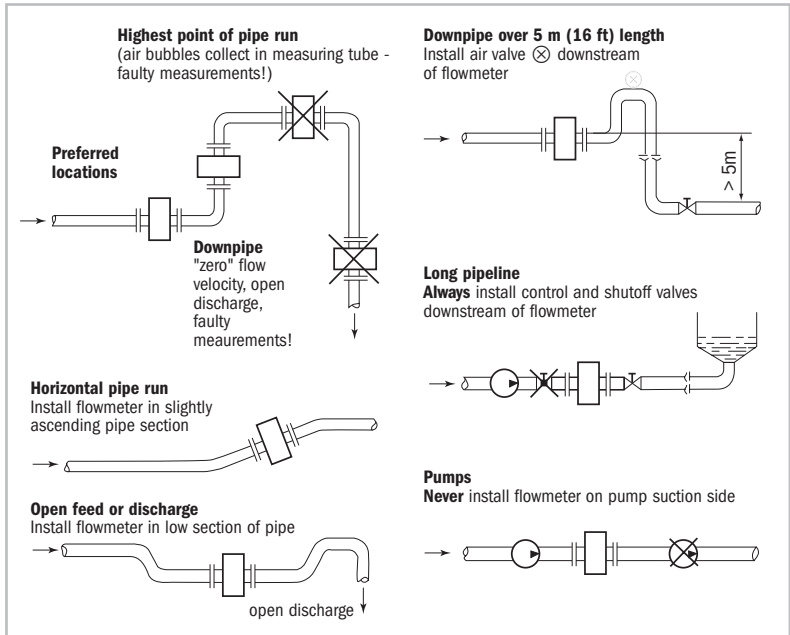

Ambient electrical conditions

EMFs are nowadays installed in the vicinity of electric melting furnaces with power capacities in the megawatt range, as well as in chlorine electrolysis plants only a few metres away from busbars carrying some 10 kA. They are fairly immune to electrical and magnetic effects.

Sound advice: discuss type selection and installation in such areas beforehand with the EMF manufacturer!

Accessibility

EMFs are measuring devices that can, and probably will, fail at some time or other. Although they will only rarely need to be dismantled, they should nevertheless be accessible! In particular, compact devices should be readily accessible for any parameter changes (e.g. full-scale range) or to allow replacement of the electronic unit if it needs upgrading or has become defective.

Installation location of the signal converter (electronic unit)**Accessibility**

Signal converters with local display: at eye level!
Compact devices should also be easily accessible!

No vibration

Install remote signal converters as a fixed installation on vibration-free suspension device.
Compact devices: support pipeline on both sides of the device.

Protection against submersion

Install signal converters outside the area at risk of submersion.

Protection against sunlight

Direct solar radiation can heat up the signal converter to 80°C (175°F) and more! The failure rate of electronic components then will increase by a factor of approx. 60.
Therefore: do not expose to direct sunlight!
When installed in outdoor plants, fit lightning protection if necessary.
Consult the EMF manufacturers.

Signal cable for remote signal converters

Lay signal cable as a fixed installation and free from vibration. Where there is risk of damp, moisture, or when laying underground: use a signal cable suitable for underground and underwater installation (standard with some EMF manufacturers). Be aware of allowable cable lengths! Do not lay near power cables!

Grounding of the EMF

Being electrical equipment, EMFs must be grounded in accordance with the applicable safety regulations (e.g. protective grounding).

Need for grounding

In addition to safety grounding, the EMF must as a rule also be grounded for metrological reasons. The signal voltage of the EMF is typically one millivolt or less. The signal converter can only process such small signals without interference if this voltage is referred to a fixed potential ("ground"). The following describes only the principle of grounding the EMF; in the individual case the installation instructions of the manufacturer will need to be followed.

Grounding in pipelines that are electrically conductive inside (e.g. stainless steel pipelines)

The EMF is electrically connected to the pipeline in an equipotential bonding sense. The pipeline is grounded, thus providing a fixed reference potential for the process liquid and the signal voltage (see left-hand figure on page 50).

Grounding in pipelines with electrically insulating inside walls

In pipelines made of plastics or concrete, or those which have an insulating lining or coating inside, the process liquid needs to be grounded by additional measures.

For this purpose, metal grounding rings are normally used whose inside face is in contact with the process liquid and which are fitted and grounded between the pipe and flowmeter flanges (see right-hand figure "metal pipelines, with or without internal coating, and plastics pipelines").

Grounding diagrams

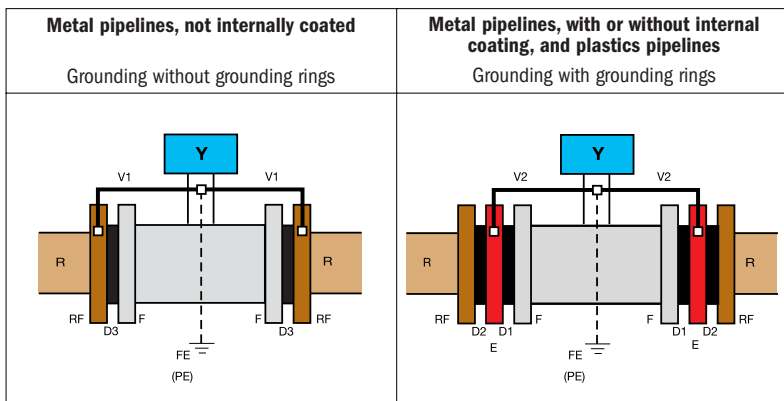

- D1, D2, D3** Gaskets, not included with supply, to be provided by customer
E Grounding rings (option)
F Flowmeter flanges
FE Functional ground, cable > 4 mm² Cu, not included with flowmeter, to be provided by customer
PE Protective conductor required if the IFS 4000 F is operated together with a signal converter supplying a field current of > 125 mA / > 60 V
 Cable ≥ 4 mm Cu (10 AWG), not included with flowmeter, to be provided by customer.
R Pipeline
RF Pipe flanges
V1, V2 Interconnecting wires, included with flowmeter
Y Terminal box or signal converter

Grounding can also be achieved by using additional ground electrodes in the EMF, which in some cases are less expensive than grounding rings. However, it must be ensured that there are no noticeable potential differences in the system, otherwise these ground electrodes can be irreparably damaged by electrolytical action.

Consequence: complete destruction of the EMF.

When ground electrodes are used for large EMFs, distinct positive measurement deviations can occur, moreover, if the EMF had been calibrated in a pipeline that is electrically conductive inside (which can be presumed!).

Installation

DN > 200 (8"): use adapter pipes to allow axial shifting!

Adapter pipes are recommended to facilitate installation and dismantling and to compensate for pipe tolerances (install behind the flowmeter).

Gaskets

The flowmeter liner usually covers the raised faces of the EMF flange, so additional gaskets are normally not needed for flowmeters with PTFE, PFA, Neoprene, soft rubber or polyurethane liners.

Torque

The torque values for the flange bolts are specified in the EMF installation instructions. These should be strictly followed as otherwise the liner in contact with the raised face of the flowmeter flange or the supplied gaskets are likely to be damaged.

Cable entries

Use cables of correct diameter, otherwise the screwed conduit entry ('PG') will not seal properly. Seal cable entries properly, lay cables with U-bend (water drip point!).

Special versions for special applications

EMFs for partially filled pipelines

Absolute requirement:

The pipelines in sewage and wastewater systems are normally not completely filled, so the classic EMFs had to be installed in a sluice underpass pipe to ensure that the pipeline is completely full. That costs money and requires continual maintenance to avoid plugging.

Sectional drawing and principle of an EMF for partially filled pipelines (KROHNE TIDALFLUX)

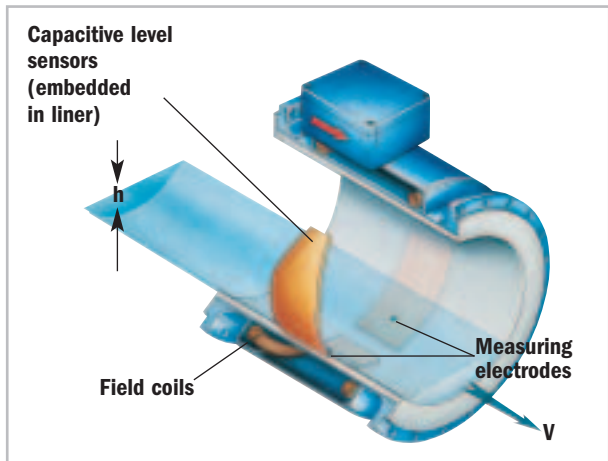

- Flow velocity v is electromagnetically measured
- Filling level h is determined by the capacitive level sensors embedded in the pipe wall
- Flow cross-section A is calculated from level h .
- Flowrate q is calculated from flow velocity v and flow cross-section A :

$$q = v \cdot A$$

The principle of EMF flow measurement in partially filled pipelines

The configuration of EMFs for partially filled pipelines is similar to that of EMFs for completely filled pipelines. However, the flowmeter for partially filled pipelines has at least one pair of low-lying electrodes on a horizontal axis at a level of approx. $0.1 \times D$ above the bottom of the pipe for sensing signal voltage and flow velocity even at low levels of flow in the pipeline.

In addition, it has equipment to measure the filling level in the measuring tube. The filled cross-section of flow is determined from the filling level. The signal converter then calculates the flowrate in the partially filled pipeline from the measured variables "flow velocity" and "filled cross-section".

Points to be given special consideration:

- The EMF for partially filled pipelines starts measuring only when the minimum filling level (10% of the diameter) has been reached. The minimum flowrate at which measurement begins depends on the pipe gradient and roughness of the pipe wall, but is typically approx. 2.5% of the flowrate in a completely filled measuring tube.
- The inflow conditions for EMFs in open channels are more difficult to control than in completely filled pipelines, because often the exposed surface of the flow, depending on the kind of disturbance, becomes calm only after very long stretches.
- EMFs for partially filled pipelines are available in the DN range of 150 (200) - 2000 mm (8" - 72").

Fast volumetric filling applications using EMFs

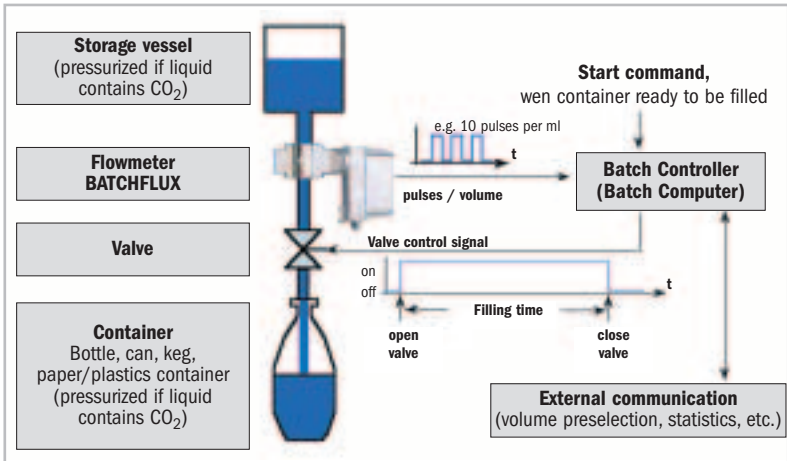

Since the introduction of the PET bottle, volumetric bottling of beverages is increasingly gaining in importance.

In this connection, the flowmeters have to satisfy not only the strict hygiene requirements imposed in the food and beverage industry but also dynamic requirements. The flowmeter is required to determine the batched volume within a few seconds to per mil reproducibility.

Because of its smooth, crevice-free tube that is easy to clean and sterilize without causing any additional drop in pressure, the EMF is absolutely predestined for such applications. In this case, too, EMFs with ceramic measuring tubes are used because of their ultra-smooth walls, dimensional stability, cleanability and pressure independence.

Special EMF versions have been developed for such applications on filling machines, which often have 100 filling points and more [14], [15]. Besides satisfying requirements for very high repeatability, very good dynamic response and food hygiene, they also meet the wish for minimum installation dimensions. The figure below shows a typical arrangement of such a filling station. Each filling point has several connections to the batch controller. These numerous cable connections and the large number of totalizer inputs in the central batch controller add considerably to the cost of such large filling machines. For that and other reasons, there is a trend to integrate the batch controller into the flowmeter. The solution with batch controller integral with every EMF means that a data bus (e.g. CAN bus) can link all flowmeters to a central computer (see figure below).

EMF with integrated batch computer controls the valve

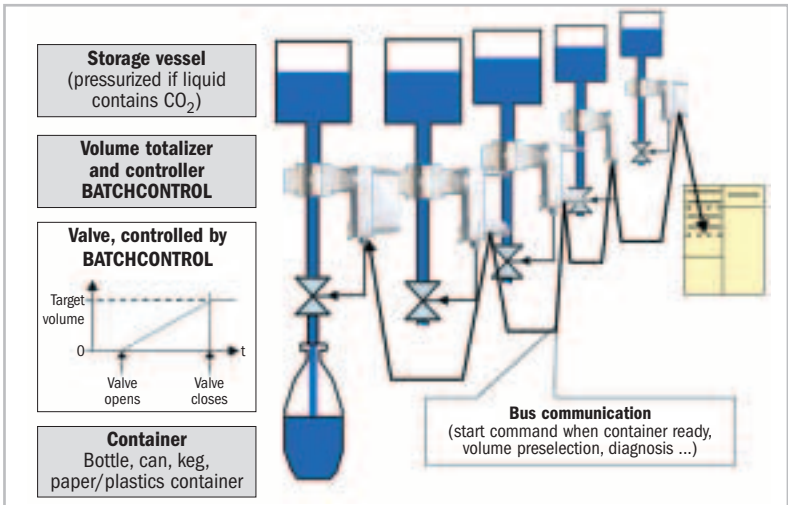

All necessary data (e.g. setpoints for the filling quantity, start signal to begin filling when the container is in place, "ready" signal from the batch controller in the EMF) are transmitted via this bus connection from and to the central computer.

The batch controller in the EMF opens the filling valve, counts the volume, calculates corrections and can also control the flowrate at the start and end of filling via multi-stage valves in finely set stages. All that is then needed, in the most favourable case, is a bus connection from all filling EMFs to the central computer. This method can improve filling accuracy, reduce the number of cable connections, and can thus help towards reducing costs and increasing reliability.

Electromagnetic flow probes

Principle

Electromagnetic flow probes are sensing probes that project into the pipeline and measure the velocity of flow at the tip (see following figure).

Given sufficiently long inlet runs (normally $> 20 \times D$), and Newtonian fluids with undisturbed radial-symmetrical flow profiles, it is possible to calculate the total flowrate from the measured flow velocity. Compared to Pitot tube or vane sensors, electromagnetic flow probes have the advantage that they work without mechanically moving parts, are largely immune to contamination and completely insensitive to overload conditions. Also, sporadically entrained solid particles do not cause any immediate damage.

Range of application

Electromagnetic flow probes are on the one hand used as limit contacts e.g. for pump protection, and on the other as flow governors with continuous display.

These devices can be used for media with adequate electrical conductivity and relatively low solids contents.

Installation

To minimize the display's dependence on the Reynolds' number, also where a turbulent flow profile is involved, it is advisable to locate the tip of the probe a distance of $1/8$ th of the inside pipe diameter away from the inside pipe wall. Markings on the weld-in socket will help to comply with this installation instruction. Electromagnetic flow probes should be installed laterally on the pipeline with an unimpeded straight inlet run of at least $20 \times D$ (follow manufacturer's installation instructions).



Electromagnetic flow probe DWM 2000 in fitting for the food industry

Applications with special requirements

Use in hazardous areas

Electromagnetic flowmeters are certified for use in hazardous areas. The types of ignition protection, and the allowable installation and application conditions are dependent on manufacturer and type. For EMFs with intrinsically safe outputs, this also applies to the allowable cable lengths for the output signals. For EMFs with remote signal converter, the length of the cables between primary head and signal converter also needs to be observed.

Custody transfer

Depending on manufacturer and type, type approvals (conformity certificates) exist for the volumetric flowmetering of cold water and for liquids other than water, and as the volumetric measuring parts of a metering instrument for thermal energy.

Measurement of pulsating flows

The following basic conditions need to be placed on the signal processing system.

- It must be capable of fast and accurate linear processing of peak flow values that can be higher by a factor of < 3 than the mean flowrate, without saturation and without overranging.
- The sampling frequency (the number of sampled values per unit time, see figure on page 27) should be at least 10 times higher than the maximum occurring pulsation frequency.
- The set time constant of the signal converter should be high enough to ensure that flow pulsations can be sufficiently well averaged to obtain steady readings.

EMF suitability for this application is dependent on type and manufacturer. For that reason, such applications needs to be discussed with the suppliers before the device is ordered!

Use in areas with strong magnetic fields

EMFs are also operated e.g. in the vicinity of electrode feeder lines for electric melting furnaces and in electrolysis plants where >10 kA currents cause build-up of sizeable magnetic fields. In such cases, the EMF suppliers will need to be consulted on the right selection of type and proper (sometimes more expensive) installation to ensure proper operation of the EMF.

Maintenance and testing of EMFs**Maintenance-free? Basically yes!**

EMFs operate without any mechanically moving parts and so basically never wear out. Many EMFs in service have been doing their job quietly and unnoticed for decades without requiring maintenance or recalibration. Maintenance therefore relates primarily to controls for signs of damage due to external influence, to deposits and the effect of abrasion in the measuring tube, and the usual failure modes. At all events, inspections should be carried out from time to time – as for all fittings in pipelines.

In addition, appropriate tests are recommended to check that the EMF is maintaining its specified measuring accuracy. The most important controls first of all:

Are the flange gaskets tight?

Leakages at the gaskets can lead to corrosion damage to the flanges, can cause the process liquid to leak into the flowmeter thus leading to measurement failure. Defective gaskets should be replaced, and the torques specified by the EMF manufacturer observed.

Are the terminal compartments of primary head or signal converter dry?

Moisture in the terminal compartments can lead to measurement errors or total failure. The cause of the leakage should be rectified.

Damp terminal compartments must be dried out before they are closed, after which an electrical test should be carried out (see below and also refer to the operating instructions issued by the manufacturer).

Testing the ground connections for corrosion

Ground connections can corrode. The connections at the EMF and the connections of the ground conductors should be tested through to the central grounding electrode.

Check for vibration, water hammer

Heavy vibration and water hammer in the pipeline can occur downstream of positive-displacement pumps or if quick-closing valves are installed. This can cause damage to compact EMFs in particular. Given heavy vibration, the pipeline should be supported on both sides of the EMF.

Inspect the measuring tube for deposits and abrasion

Some liquid products have a tendency to form deposits or incrustations, in which case the measuring tube should be cleaned from time to time.

Cleaning methods and cleaning intervals will depend on the process and on the type of the deposits.

Abrasive action will change the inside diameter of the measuring tube. The resultant measurement errors can be corrected by recalibrating the flowmeter. If the liner wears thin, a short-time total failure can be expected. For that reason, EMFs with such damage should be refitted with a new liner by the manufacturer, or replaced altogether.

Testing of accuracy by calibration on an accredited test rig

The EMF can be tested for accuracy by the manufacturer or a flow calibration laboratory. The EMF would need to be removed from the pipeline for this purpose, which is a time-consuming job but also enables the electrodes and liner to be checked and cleaned at the same time.

Testing and documentation using intelligent testing equipment

The above "by calibration" method is a costly process and usually causes a short downtime or can only be carried out when the plant is at a standstill. For that reason, EMF testing devices are available which enable the flow-meter to be tested without removing it from the pipeline and also provide information on its functional accuracy.



*EMF MagCheck:
tests and certifies
EMFs*

The newest generation reads out all set operating parameters and stores them via the device bus. A test program then runs automatically to test

- the electrode resistance,
- the field coil resistance and insulation,
- the accuracy and linearity of primary signal processing and all outputs.

The measured data are first stored in the testing device (the KROHNE MagCheck can save up to 70 data sets, without (rechargeable) battery or external power connection during device testing). These data are then downloaded to a PC.

A special program

- evaluates these data against preset limit values,
- compares the current set data with those from the last test,
- issues a warning in the event of changes,
- creates trend analyses of all data for each measuring point, and
- creates a test certificate certifying that, in terms of its electrical and electronic functions, the EMF has a measuring error of less than 1% compared to the initial calibration when all measured data were perfect.

Proven technology of EMFs

Well over three million EMFs are currently (2003) in operation throughout the world: for example, on dredging boats measuring the flowrate of dredged material from the Red Sea; measuring and totalling the volumetric flowrate of potable water and wastewater [12], adding flocculants and chlorine solutions; measuring bauxite slurries in Australia, hot phosphoric acid and caustic soda in chemical works, and precisely batching cold cola into bottles in a matter of seconds.

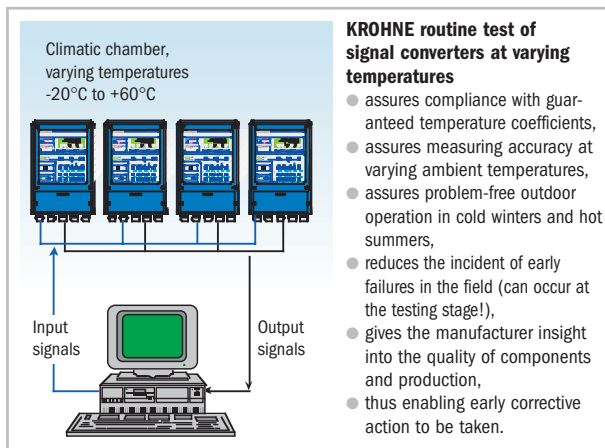

Burn-in test at varying temperatures assures high reliability

The EMF has become a rugged measuring device which, after more than 50 years in industrial service has proven its high reliability, accuracy and stability on a daily basis in the most varied applications.

Thanks to its high reliability and accuracy, low maintenance requirement, low power consumption and owing to the negligible drop in pressure, the EMF ranks among the flowmeters with the lowest operating costs (cost of ownership).

Burn-in tests contribute towards its high reliability and low maintenance requirement which KROHNE carries out as a 100% standard routine test on each signal converter before it leaves the factory (for principle, see figure on page 63). This in-house test at varying temperatures pre-empts early failure of the electronic components, thus dramatically increasing reliability in the field.

The pre-delivery calibration of every single flowmeter on test rigs subject to official controls and, at some manufacturers, accredited to EN 17025, is a further point to assure quality of measurement and saves the customer having to perform laborious routine tests and "local calibrations" (for principle, see next figure).

The range of application has been further extended in recent years by the introduction of two-wire EMFs, of EMFs for partially filled pipelines and high-speed filling processes, and by "no-electrode EMFs" for difficult media.

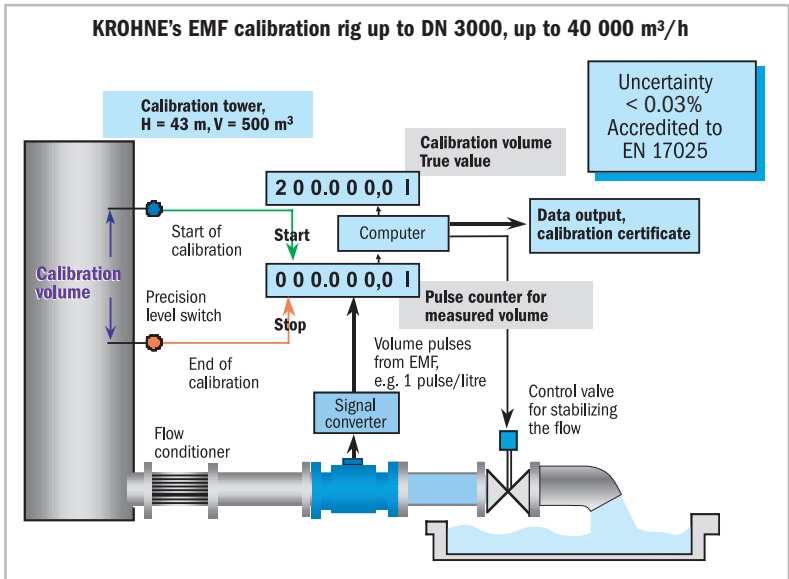

Intelligent testing devices with data evaluation, with unerring assessment and trend analyses on the PC, simplify EMF testing and maintenance and verify that the measuring point is functioning properly.

With these new methods, processes and devices, the advantages of electromagnetic flow measurement can also now be exploited in sectors where previously no suitable flow measurement process had been available.

Necessary details for suppliers

Process liquid

- Designation (if necessary with formula), concentration, conductivity
If solids content:
 - Type of solids (designation),
particle density
 - Particle sizes
 - Weight per cent (density if necessary) of total slurry

Operating conditions

- Operating pressure
- Process temperature
- Flow rate: maximum value
Constant? If not:
 - for short times?
Describe planned application
(e.g. filling process 3-7 s, filling volume 0.4 - 1 litre)
 - Pulsating without pulsation damper?
Indicate stroke frequency, type of pump
(no. of displacers, single-stroke, two-stroke, ...)

Device type - primary head / signal converter

- Type
- Compact / separate system (if separate, also order signal cable)
- Power supply (two-wire or multiwire EMF? If multiwire, what voltage?)
- Type of protection
- Explosion protection required?
- Process connections:
 - DN meter size
 - Operating / design / nominal pressure
(For a larger DN size, it can save money if not only the nominal pressure but also the design pressure is specified for defining the flange hole circle!)
- Liner,
- Electrode material
- Grounding rings: yes (if so, specify material) / no?

Reference to special operating conditions

- Extreme magnetic fields (electric melting furnaces, electrolysis plants)
- Very high solids contents (see above)

Setting data, e.g.

- Required full-scale range
- Analog output 4 - 20 or 0 - 20 mA
- Output settings

KROHNE will make all EMF settings to your specification.
Install, connect up, switch on, it's ready to operate.

Additional requirements

- Special approvals
- Material certificates
- Tests, test certificates

Standards**relating to electromagnetic flowmeters and testing thereof**

DIN 19200
EN 29104, ISO 9104
DVGW W420, ISO 13359
ISO 6817
OIML R 117

Bibliography

- [1] Faraday, M.
Experimental Researches in Electricity, Phi.Trans. 15 (1832),
p. 175 3
- [2] Thürlemann, B.
Methode zur elektrischen Geschwindigkeitsmessung in
Flüssigkeiten.
Helv. Phys. Acta 14 (1941), pp. 383-419 3
- [3] Shercliff, J.A.
Relation between the velocity profile and sensitivity of
electromagnetic flowmeters.
J. Apply. Phys. 25 (1954), p. 817 3
- [4] Engl. W.L.
Der inductive Durchflussmesser mit inhomogenem
Magnetfeld.
Archiv für Elektrotechnik, Vol. 53, 1970 and Vol. 54, 1972 4
- [5] G. Schommartz:
Induktive Strömungsmessung.
VEB Verlag Technik Berlin (1974).
- [6] Polly, P., Reinhold, I.:
Der Einfluss der Symmetrie-Eigenschaften des Strömungs-
profiles beim induktiven Durchflussgerätes, AM "Archiv für
technisches Messen", Lfg. 464, H 9/74, pp. 153-158
- [7] Bonfig, K.W., Hofmann, F.
Die Technik der magnetisch-induktiven Durchflussmessung,
ATM, Lfg. 473, H. 6/75, H. 7,8/75
- [8] Reinhold I.
Magnetfeldformung und Meßgenauigkeit beim magnetisch-
induktiven Durchflussgerät. Archiv für technisches Messen,
Lfg. 476, H.9/75, 139-144 4
- [9] Keine, W.
Magnetisch-induktive Durchflußgeräte.
Messen + prüfen, automatik 6/1976, pp. 316-331 4

- [10] F. Hofmann, M.H.C. Janssen
Magnetisch-induktive Durchflußmessung mit kapazitiver
Signalauskopplung
KROHNE MSR-Technik 6/1976
- [11] Tsangaris, S., Leiter, E.:
Strömungs-Asymmetrie bei induktiver Durchflussmessung.
Technisches Messen tm, Vol. 48, No. 6/1981
- [12] Hofmann, F.:
Universität – Gesamthochschule Kassel,
Special field: domestic water supplies;
Hirthammer-Verlag München, ISBN 3-88721-117-0:
Magnetisch-induktive Durchflussmessung auf Kläranlagen,
Grundlagen und Anwendungen
- [13] Brockhaus, H., Klein, J.W., van der Pol, Ronald, Schoth, U.:
Kapazitiver magnetisch-induktiver Durchflussgeräte unter
Verwendung der Mikrosystemtechnik,
Sensoren und Sensorsignalverarbeitung, Vol. 8, p. 187, 1997,
ISBN 3-3-8169-1428-4
- [14] Hofmann, F.:
Volumetric Filling using Electromagnetic Flowmeters,
drink technology & marketing 09/1999
- [15] Hofmann, F.:
Magnetisch-induktive Durchflussgeräte aus Edelstahl:
Für kompakte volumetrische Füllanlagen Dei 5/2000
- [16] Brockhaus, H.:
Magnetisch-induktives Durchflussgerät, versorgt über
die 4-20 mA-Schnittstelle
atp Automatisierungstechnische Praxis 11/2000

List of illustrations

- Page 06 Principle of the electromagnetic flowmeter (EMF)
- Page 09 Valence function of the EMF model, after Schercliff
- Page 10 View into the measuring tube of an EMF (example: tube with Teflon®-PFA liner, Hastelloy electrodes)
- Page 12 EMF CAPAFLUX with capacitive signal pick-up and Al₂O₃ ceramics measuring tube)
- Page 15 Functional units in a μ P EMF signal converter
- Page 16 Internal bus structure (IMoCom) of the KROHNE μ P EMF signal converter IFC 110
- Page 17 Free pipe cross-sectional area
- Page 18 Typical limits of error of an EMF at reference conditions
- Page 19 Flow profile influence, EMF
- Page 20 Pulsating flow (170 strokes/min), at the outlet of a diaphragm pump. Measured with KROHNE EMF IFC 110 with pulsed dc field
- Page 27 Typical time characteristic of field current and electrode voltage in an EMF with pulsed dc field
- Page 29 Multiwire EMF, principle
- Page 30 Two-wire EMF, principle
- Page 31 Two-wire EMF ALTOFLUX 2W from KROHNE, flanged design
- Page 33 EMF primary head of flanged design, ALTOFLUX DN 3000 mm, measuring range 0 – 100,000 m³/h
- Page 34 Sandwich EMF KROHNE PROFIFLUX 5000 with flow-optimizing Al₂O₃ ceramic measuring tube
- Page 35 Sanitary EMF VARIFLUX 6000, compact design, with L-shaped gasket with trapezoidal sealing lip between lined measuring tube and process pipe or adapter

- Page 36 Flanged EMF of 'separate-system' design:
ALTOFLUX 4000 with IFC 110
- Page 37 Shielded KROHNE signal cable, type DS,
for separate-system EMF
- Page 38 Flanged EMF ALTOFLUX 4080 K, compact design
- Page 39 Pipeline reducers upstream and downstream of the EMF
- Page 43 Field replaceable electrode (removable under pressure
for cleaning)
- Page 44 Selection criteria: integral or remote signal converter
- Page 45 Flanged or sandwich EMF
- Page 47 Suggested installation locations
- Page 50 Examples of grounding the EMF
- Page 52 Sectional drawing and principle of an EMF for
partially filled pipelines (KROHNE TIDALFUX)
- Page 54 Fast volumetric filling with EMF
- Page 55 Integrated batch computer controls valve
- Page 57 Electromagnetic flow probe DWM 2000 in fitting for the
food industry
- Page 61 EMF MagCheck tests and certifies EMFs
- Page 63 Burn-in test at varying temperatures assures high
reliability
- Page 65 KROHNE calibration rig for EMFs up to meter size
DN 3000, 40 000 m³/h (principle)

Tables:

- Page 41 Properties of various measuring tube and
liner materials
- Page 42 Hints for selecting electrode material
- Page 44 Selection "compact" / "separate system"
- Page 45 Selection "flanged" / "sandwich"



Dipl.-Ing. Friedrich Hofmann has been with KROHNE for more than 30 years in various positions responsible for flow measurement. As Head of Development he was responsible for the first generation of EMFs with pulsed dc field, for radiometric density measurement and for ultrasonic sludge level measurement.

Under his guidance, KROHNE was the first manufacturer of EMFs to initiate the rapid transition from the ac field to the pulsed dc field. The upside was that the EMF developed from an expensive high-maintenance “exotic” for extreme applications into a standard industrial measuring device that is both operationally reliable and maintenance-free.

Here and in subsequent positions in Sales, Service and Product Marketing, and from the advisory services, expertise and technical support he has provided, also for extreme applications, Friedrich Hofmann has gained the experience that he is passing on in KROHNE's Flow publications.

United Kingdom

KROHNE Ltd.
Rutherford Drive
Park Farm Industrial Estate
Wellingborough,
Northants NN8 6AE, UK
TEL.: +44(0)19 33-408 500
FAX: +44(0)19 33-408 501
e-mail: info@krohne.co.uk

USA

KROHNE Inc.
7 Dearborn Road
Peabody, MA 01960
TEL.: +1-978 535-6060
FAX: +1-978 535-1720
e-mail: info@krohne.com

Other countries

KROHNE Messtechnik GmbH & Co. KG
Ludwig-Krohne-Str. 5
D-47058 Duisburg
TEL.: +49(0)203-301-0
FAX: +49(0)203-301 389
e-mail: info@krohne.de