

Thermo Scientific Orion Chlorine XP Analyzer

Multiple parameter water quality analyzer

From brine and wastewater to clean drinking water, the Thermo Scientific™ Orion™ Chlorine XP™ analyzer is designed to provide accurate, stable measurements of routine water quality parameters. With minimal maintenance, low cost of ownership, and multiple parameter measurement in one unit, the Orion Chlorine XP analyzer is a comprehensive water quality monitor.



The Orion Chlorine XP analyzer measures free, total, and both free-total chlorine in water. Design features help minimize the need for periodic calibrations and offer compatibility with many disinfectant processes. It utilizes an optical DPD-reagent based measurement technology that can be configured to use the least amount of reagents while maintaining outstanding accuracy.

High Performance & Reliability

- Outstanding performance in harsh sample conditions (sea water, colored water, oil-water mix)
- 0-10 ppm measurement range in most applications
- Self zero calibration before each reading, enables "0" reading
- Wet tested for 24 hours before shipping
- 2 year warranty ⁽¹⁾

Low Price & Cost of Ownership

- Free and total chlorine and pH, temperature (optional ORP, conductivity, and turbidity) in one analyzer – saves from purchasing separate analyzers
- Low and customizable reagent consumption (default ~0.033 ml/sample) – can last up to 2 months at 5 minute cycle times

Low Maintenance

- Light source self calibration adjustment
- Hands-free self cleansing of the photocell
- Automatic elimination of bubbling in the photocell
- Maintenance reminders and alarms (once a year on average)
- Auto buffer recognition at 4, 7, and 10

Additional Features

- Up to 6, 4-20 mA isolated current outputs
- 6 relays
- RS 485, Modbus® protocol support
- Optional Ethernet protocol to operations center



Markets:

- Drinking Water
- Wastewater
- Food and Beverage
- Industrial

Applications

The Chlorine XP analyzer can be used as a general purpose chlorine measurement analyzer along with other parameters – pH, temperature, ORP, and flow in water quality measurement applications.



Drinking Water Treatment - Most drinking water plants use chlorine as a preferred method of water disinfection and distribution monitoring. The Chlorine XP analyzer is designed to provide rapid feedback for chlorine dosing in water disinfection, as well as monitoring for chlorine levels during water distribution. Using an EPA approved DPD method with up to two months of reagent usage, the Chlorine XP analyzer is designed to deliver lower operating costs.



Wastewater Treatment - Most wastewater plants use chlorine as a preferred method of disinfection before releasing water into the environment. The Chlorine XP analyzer is designed to accurately measure both total and free chlorine continuously prior to discharge, which helps prevent over-chlorinated water from being released into the environment. This combination of measurements helps eliminate the use of two different instruments, resulting in reduced operating costs for the plant.



Power Generation - Power plants measure free and total chlorine for cooling water effluent to meet the regulatory limits for chlorine discharge. The Chlorine XP analyzer measures as low as 10 ppb for total chlorine in seawater, which is well below the minimum detection limits for most regulatory standards.



Food and Beverage Manufacturing - Food and beverage plants need to measure chlorine before water goes through the reverse osmosis (RO) process. This is because chlorine can shorten the life of the RO membrane by chemically reacting with the membrane. The Chlorine XP analyzer is designed to provide low level detection (up to 10 ppb) and a quick response time, extending the life span of RO membranes which helps reduce operating costs for the plant.

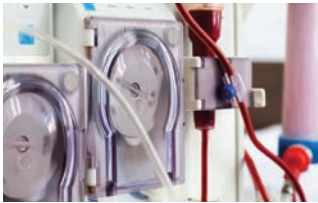

Dialysis Treatment - Dialysis treatment centers monitor the chlorine level in kidney dialysis machines to make sure that it doesn't come into contact with blood. Chlorine/chloramines in water used for dialysis can result in serious adverse patient reactions. The Chlorine XP analyzer is designed to measure less than 0.5 ppm (max. limit) total chlorine and provide quick response time, resulting in RO life extension and improved carbon filter efficiency.

The operating system is designed to be simple and intuitive. Once installed and calibrated, the Chlorine XP analyzer automatically releases the proper quantity of chemicals depending on measurement frequency. The standard Chlorine XP analyzer model comes with chlorine measurement, and can be configured to measure any combination of free chlorine, total chlorine, and both free-total chlorine.



The DPD (N, N-diethyl-p-phenylenediamine) method for residual chlorine was first introduced by Dr. A.T. Palin in 1957⁽²⁾. Over the years it has become the standard method for determining free and total chlorine in water and wastewater. When DPD reacts with small amounts of chlorine at a near neutral pH, a colored dye is the principal oxidation product. The DPD dye color is measured photometrically at wavelengths ranging from 490 to 555 nanometers (nm), which results in accurate reading of both free and total chlorine concentrations in water.

Free chlorine (hypochlorous acid + hypochlorite ions) reacts with the Free Chlorine Indicator (DPD1) causing a color change in the sample from clear to red. The buffer is used to ensure reaction at a consistent pH. The more free chlorine that is present, the darker the red color that forms. The color intensity is proportional to concentration as specified by the Beer-Lambert law.

Total chlorine is often used for monitoring combined chlorine (chloramines) levels. The presence of chloramines is an indicator of the level of organics present and can reduce the ability to disinfect the sample adequately. Combined chlorine is the difference between the total chlorine and free chlorine. When free chlorine and total chlorine need to be measured in sequence, the Total Chlorine Indicator (DPD3) is added to the sample already containing the Free Chlorine Indicator (DPD1) and buffer. The combined chlorine reacts with the Total Chlorine Indicator causing an increase in the red color. The total chlorine is determined from the color change and the combined chlorine is calculated from the difference between the total and free chlorine. When only total chlorine test is needed, the Total Chlorine Indicator (DPD4) is added to the sample causing color change and the levels of total chlorine is determined.

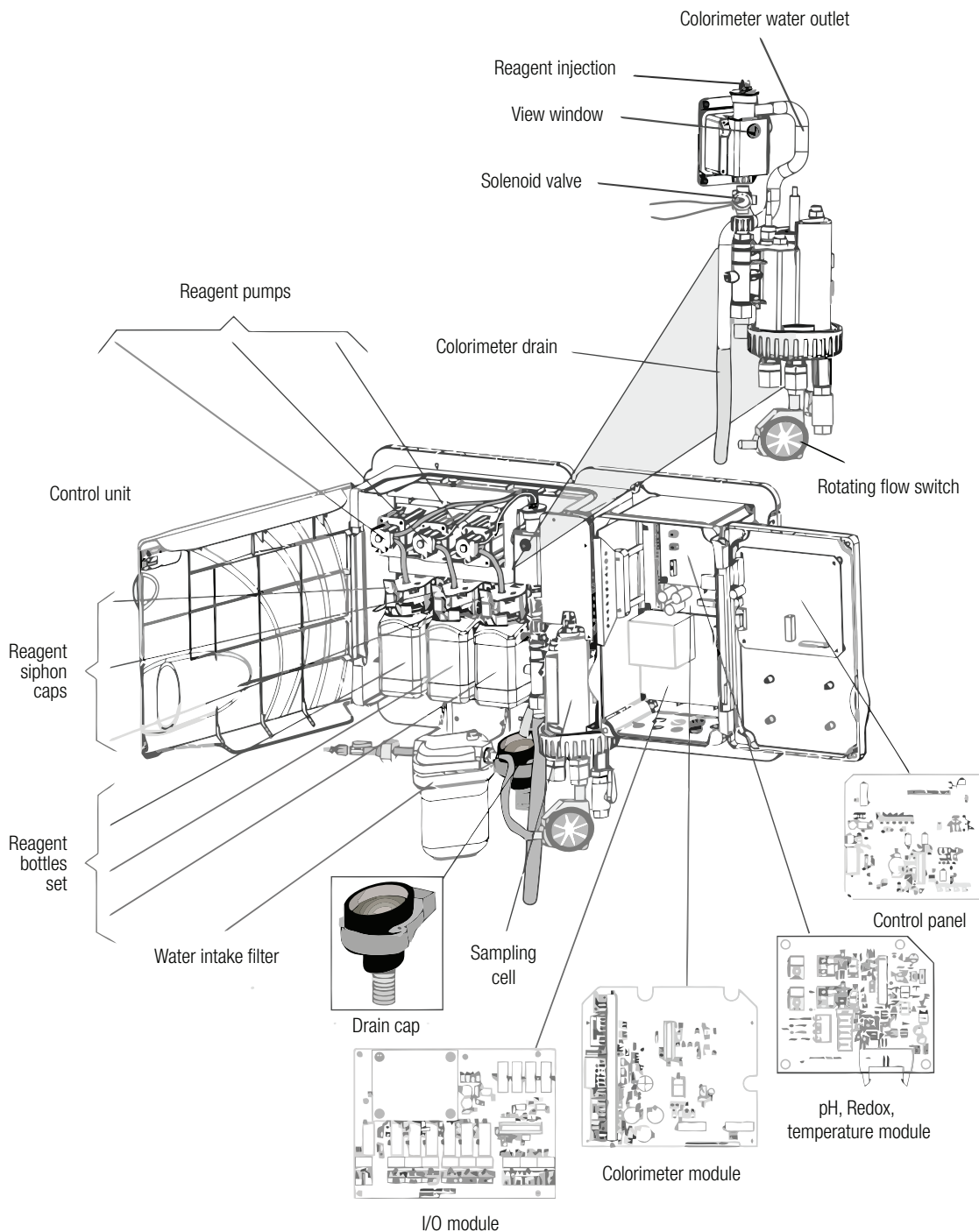

Product Specifications

Performance		Options/features	
Accuracy	±5 %	Alarms	Optional, see manual
Repeatability	±0.01 mg/L	Enclosure	IP65-rated enclosures (NEMA 4 equivalent)
Minimum Detection Limit	10 ppb	Local I/O	2 standard 4-20 mA outputs 4 optional 4-20 mA outputs
Zero-Point-Adjustment	Self zero before each reading	Memory	256 K
Cycle Time	2 to 10 minutes	Lines	1000
Flow Monitoring	Rotary flow switch (see Additional Requirements section for inlet/outlet pressure)	Event Logger	Yes
Parameters	FC, TC, F&TC, ORP, pH, Temp.	Total Relay On Time	Yes
Measuring Range	0 to 10 ppm (Chlorine); 0-14 (pH)	Display Type	5.5 in graphic monochromatic; character LCD with background light alarms and status
Reliability		Password	Operator and technician
Warranty	2 years ⁽¹⁾	Servicing/ Maintenance	Self-cleaning photocell (minimum service requirement)
Validation	Contact factory	Additional Requirements	
USEPA Accepted Method ⁽³⁾	Yes	Sample and Drain Connection	Pressurized sample inlet and gravity drain
CSA Certified	Yes	Sample Temperature	32 °F to 212 °F (0 °C to 100 °C) Ambient Temperature: 15 °F to 131 °F; (-10 °C to 55 °C)
CE Certified	Yes	Inlet Pressure	5-15 psi
Operations Requirements		Sample Conditioning	Not required
Maintenance	1-2 months for reagent replacement and filter cleaning		
Calibration	Every 6 months (pH and ORP only)		
Reagent Usage	DPD up to 2 months at 5 min. cycle time		
Power Consumption	Approx. 60 VA		
Power Supply	100-115 VAC, 50/60 Hz, 1.0 A or 200-230 VAC, 50/60 Hz, 0.5 A		
Weight	24 lbs (11 kg)		
Dimensions (W x H x D)	67 cm x 33 cm x 14 cm, 26.0 in x 13.0 in x 5.5 in		

Product Ordering Information

Cat. No.	Description
CXP71	Free Chlorine only with 2 x 4-20 mA outputs
CXP72	Total Chlorine only with 2 x 4-20 mA outputs
CXP73	Free & Total Chlorine combined, 2 x 4-20 mA outputs
CXP71PH	Free Chlorine + pH + Temp. 2 x 4-20 mA outputs
CXP72PH	Total Chlorine + pH + Temp. 2 x 4-20 mA outputs
CXP73PH	Free & Total Chlorine combined + pH + Temp 2 x 4-20 mA outputs
CXPRGDPD1F	5 sets of DPD1 reagents for Free Chlorine
CXPRGDPD4T	5 sets of DPD4 reagents for Total Chlorine
CXPRGDPD3T	5 sets of DPD3 reagents for Total Chlorine (need to be used with DPD1 for CXP73 and CXP73PH)

- Subject to terms of manufacturer's standard limited warranty. Please contact your sales representative for more details.
- V.A. Argent, "A Short History of Palintest Ltd.", April 2009
- Steven C. Wendelken, Derek E. Losh, and Patricia S. Fair, Office of Ground Water and Drinking Water, "EPA Method 334.0: Determination of Residual Chlorine in Drinking Water Using an On-line Chlorine Analyzer", September 2009

thermoscientific.com/processwater

© 2015 Thermo Fisher Scientific Inc. All rights reserved. Modbus is a registered trademark of Schneider Electric. All other trademarks are the property of Thermo Fisher Scientific and its subsidiaries unless otherwise specified.

Water and Lab Products

North America

Toll Free: 1-800-225-1480
Tel: 1-978-232-6000
info.water@thermofisher.com

Germany

Tel: (49) 6184-90-6000
info.water.uk@thermofisher.com

India

Tel: (91) 22-4157-8800
wai.asia@thermofisher.com

Japan

Tel: (81) 045-453-9175
wai.asia@thermofisher.com

China

Tel: (86) 21-68654588
wai.asia@thermofisher.com

Singapore

Tel: (65) 6778-6876
wai.asia@thermofisher.com

Australia

Tel: (613) 9757-4300
In Australia: (1300) 735-295
InfoWaterAU@thermofisher.com

Thermo
SCIENTIFIC

A Thermo Fisher Scientific Brand